



# UNIVAC<sup>®</sup> FILE-COMPUTER

## System Specifications

© 1987 - SPERRY RAND CORPORATION

## PREFACE

This publication is a summary of the functional and physical characteristics of the Univac File-Computer System. Its purpose is to provide company personnel with basic information on the Univac File-Computer until detailed programming, installation, and maintenance manuals are published. This summary describes the Univac File-Computer Model 0 and Model 1 as well as Univac File-Computer input-output units.

These input-output units include punched-card, magnetic tape, paper tape, keyboard, line printer and special-purpose devices.

Supplements to this resume will be issued later describing additional input-output units.

## TABLE OF CONTENTS

|   | PAGE       |
|---|------------|
| <i>INTRODUCTION</i> . . . . .   | <i>iii</i> |
| UNIVAC FILE-COMPUTER CENTRAL COMPUTERS . . . . .                                  | <b>1</b>   |
| UNIVAC FILE-COMPUTER GENERAL STORAGE SYSTEMS . . . . .                            | <b>11</b>  |
| UNIVAC FILE-COMPUTER MODEL I CONSOLE SYSTEM . . . . .                             | <b>16</b>  |
| UNIVAC FILE-COMPUTER INQUIRY TYPEWRITER . . . . .                                 | <b>19</b>  |
| UNIVAC FILE-COMPUTER 90-COLUMN CARD SYSTEM . . . . .                              | <b>23</b>  |
| UNIVAC FILE-COMPUTER 90-COLUMN CARD SYSTEM<br>(WITH POST-READ CHECKING) . . . . . | <b>27</b>  |
| UNIVAC FILE-COMPUTER 80-COLUMN CARD SYSTEM (BULL) . . . . .                       | <b>32</b>  |
| UNIVAC FILE-COMPUTER MAGNETIC TAPE UNIT . . . . .                                 | <b>38</b>  |
| UNIVAC FILE-COMPUTER SORT-COLLATE SYSTEM . . . . .                                | <b>46</b>  |
| UNIVAC FILE-COMPUTER HIGH-SPEED PRINTER . . . . .                                 | <b>65</b>  |

# Introduction

A Univac File-Computer System is an electronic data-processing system which features the simultaneous operation of:

- a Central (general-purpose) Computer;
- a large-capacity, random-access, magnetic drum memory called General Storage; and
- an integrated system of Univac File-Computer Input/Output Units and other auxiliary devices.

Time-shared (simultaneous) operation is possible because

the Central Computer, its associated General Storage, and each of the Univac File-Computer Input/Output Units operate independently under control of a computer program;

instructions or sub-instructions can be programmed to define a time-shared operation for General Storage or one of the Univac File-Computer Input/Output Units; and

the defined operation can be initiated without causing subsequent delay to the computer's execution of logical and arithmetic operations.

Once initiated, a time-shared General Storage or Univac File-Computer Input/Output Unit operation is carried out independently of the Center Computer. It is, therefore, not uncommon in the execution of Univac File-Computer System programs for

The Central Computer to be executing an arithmetic or logical operation, General Storage to be engaged in a reading or recording operation, and a variety (perhaps all) of the Univac File-Computer Input/Output Units to be operating.

Two types of Univac File-Computer Systems are available: Model 0 and Model 1. These systems differ, as explained in Sections 1 and 2, in both the Central Computer and General Storage which they include. However, any Univac File-Computer Input/Output Unit (except the Univac File-Computer Model 1 Console System), can be in either system. Up to 8 Univac File-Computer Input/Output Units, in any combination, can be simultaneously controlled in Model 0 Systems. Model 1 Systems can control up to 10 Univac File-Computer Input/Output Units, in any combination.

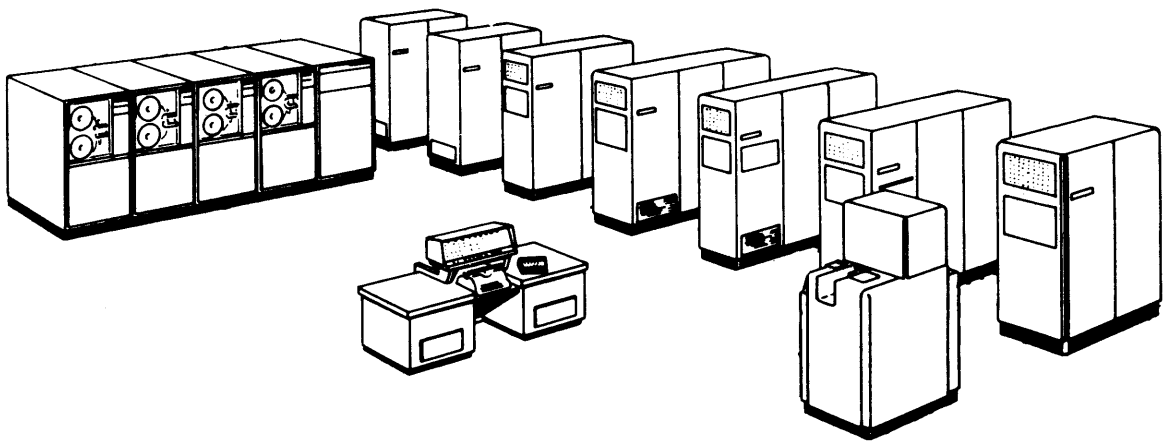

*Typical Model 1 Univac File-Computer System*

## SECTION 1

# UNIVAC FILE-COMPUTER CENTRAL COMPUTERS

Both the Model 0 and Model 1 Central Computers are general-purpose, serial, three-address, digital machines, equipped with their own operating storage. Their basic unit of data is an alphanumeric character expressed in Univac code (excess-three, binary coded decimal notation). In both computers, the standard word length manipulated in an arithmetic operation is 12 characters: 11 characters plus a sign character. Arithmetic operations are automatically checked, and the accuracy of data transmission within, as well as to and from, each machine is also automatically verified by checking a (redundant) parity-bit stored with each Univac-coded character.

### MODEL 0

The Model 0 Central Computer is a plugboard machine. Patchcord wiring on a removable connection panel (plugboard) is used to define all of its instructions and sub-instructions; and the order, or sequence, in which these instructions and sub-instructions are to be carried out. Model 0 instructions are called Program Steps; sub-instructions are called Sub-Steps.

### FUNCTIONAL DESCRIPTION

Program. A Model 0 computer program is a series of plugboard defined Program Steps each of which, in addition to defining a computer instruction, also defines the location of the next computer instruction, and/or one of more Sub-Steps.

Each Program Step consists of five basic elements:

1. The arithmetic or operational process to be performed:

|                       |                        |
|-----------------------|------------------------|
| Transfer              | Multiply               |
| Masking Transfer      | Divide                 |
| Left Zero Elimination | Compare                |
| Add                   | Channel Search Equal   |
| Subtract              | Channel Search Unequal |

2. The storage location of the first value ( $V_1$ ) upon which the process is to operate; and the number of places, if any, that value is to be shifted prior to its use in the process.
3. The storage location of the second value ( $V_2$ ) upon which the process is to operate; and the number of places, if any, that value is to be shifted prior to its use in the process.
4. The storage location to which the result of the program (R) is to be delivered; and the number of places, if any, the result is to be shifted prior to its storage.
5. The particular Plugboard Step (one of 48 numbered 57-98) where the next Program Step is located; and/or the Sub-Steps) to be initiated as the program passes to the next instruction. The following Sub-Steps are available:

|                   |                      |
|-------------------|----------------------|
| Program Select    | Demand Test In (0-7) |
| Write Unit Record | Branching            |
| Read Unit Record  | Function Delay       |
| Demand In (0-7)   | Function Sequence    |

Storage. The main operating storage of the Model 0 Central Computer is a High-Speed Magnetic Drum. Up to 13 drum tracks (120 characters per track) are used:

5 tracks for Factor or Intermediate Storage.

1 up to 8 tracks for Input/Output operations: one for each Input/Output Unit used.

A revolver in General Storage is also part of the operating memory of the Model 0 Central Computer. This revolver functions as a temporary storage for data transmissions to and from the computer and General Storage. The revolver stores a Unit Record. Up to twenty fields, F0-F19, (each 12 characters or less) can be referred to by the computer in any General Storage operation. Those fields are defined by patchcord-wiring on the General Storage Plugboard.

Input-Output System. The Model 0 Central Computer in-out system includes circuitry in both the computer and each Univac File-Computer Input/Output Unit employed. The computer circuits are those required for the execution of Demand Test In and Demand In sub-instruction sequences. The Univac File-Computer Input/Output Unit's in-out circuits are all logically identical, and are called Demand Stations.

When a Univac File-Computer Input/Output Unit is physically connected to the Computer, cabling from its Demand Station is plugged into one of eight Demand Station Positions



(0-7) in the computer. Any Univac File-Computer Input/Output Unit can be plugged into any Demand Station position. Once plugged, however, it is designated as I/O Unit "n" (where n = 0-7), and it communicates only with a correspondingly numbered I/O Track (00-07) on the High-Speed Drum.

Each Univac File-Computer Input/Output Unit Demand Station enables the computer to test the status of the Unit at any time to determine whether the Unit is READY or NOT READY for subsequent use. A Univac File-Computer Input/Output Unit is READY if it is operable and not engaged in a previously-initiated operation. It is NOT READY in all other cases. By executing the appropriate Demand Test In (0-7) sub-instruction, the computer can resume its internal computing without delay. If the Unit is READY, the computer can execute an appropriate Demand IN (0-7) sub-instruction. This sub-instruction can (a) give the Univac File-Computer Input/Output Unit an operation to perform, or (b) receive (program variance) control information from the Univac File-Computer Input/Output Unit, or in special cases, perform (a) and (b). In any case, no delay is introduced into central computer operation.

If a Unit is given an operation to perform, it places itself in a NOT READY status, and begins the defined operation. When a Univac File-Computer Input/Output Unit is in a NOT READY condition, it can carry out data transmission to and from its associated I/O Track as required in the operation specified by the computer program. When a Univac File-Computer Input/Output Unit completes the required operation, it places itself in a READY condition. The I/O Track is then connected to the computer, and is no longer available to the Unit. The computer and Univac File-Computer Input/Output Unit thus alternately share control of the Unit's I/O Track, depending on whether the Unit is in a READY or NOT READY status, respectively.

#### PHYSICAL DESCRIPTION

The Model 0 Central Computer (Figures 1-1 and 1-2) consists of two cabinets: Program Control and Arithmetic. Table 1-1 lists the Model 0 installation requirements; Figure 1-3 gives cabling information.

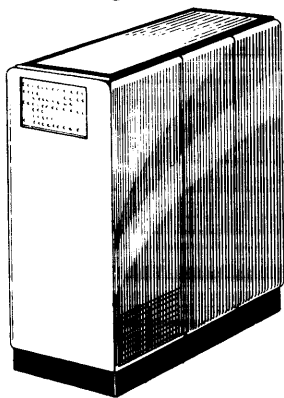

Figure 1-1.  
Model 0 Program  
Control Cabinet

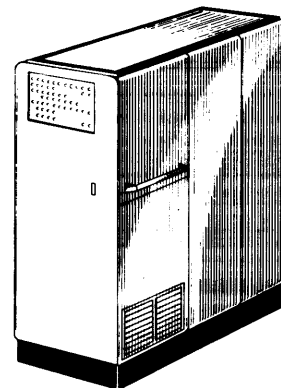
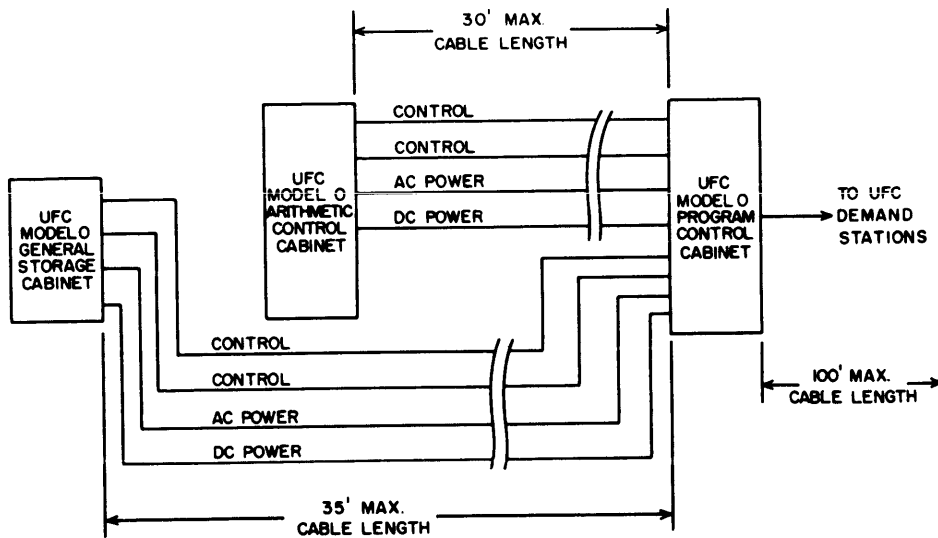

Figure 1-2. Model 0  
Arithmetic Cabinet

Table 1-1  
**INSTALLATION REQUIREMENTS  
 OF UNIVAC FILE-COMPUTER MODEL 0**

|                          | PROGRAM CONTROL CABINET | ARITHMETIC CABINET |
|--------------------------|-------------------------|--------------------|
| <b>SIZE AND WEIGHT:</b>  |                         |                    |
| WIDTH                    | 30"                     | 30"                |
| LENGTH                   | 78"                     | 74"                |
| HEIGHT                   | 71"                     | 71"                |
| WEIGHT                   | 2015 LB.                | 1279 LB.           |
| <b>CLEARANCE:</b>        |                         |                    |
| FRONT                    | 56"                     | 56"                |
| BACK                     | 30"                     | 30"                |
| RIGHT SIDE               | 42"                     | 42"                |
| LEFT SIDE                | 42"                     | 42"                |
| <b>POWER DISSIPATION</b> | 10KW                    |                    |
| <b>ELECTRIC SERVICE:</b> |                         |                    |
| KVA                      | 12                      |                    |
| VOLTS                    | 208-240 VAC             |                    |
| PHASE                    | 3Ø-4 WIRE OR 1Ø-3 WIRE  |                    |
| MAX. LINE VARIATION      | ±5%                     |                    |
| <b>COOLING:</b>          |                         |                    |
| AIR CURRENT              | 2000 CFM                |                    |
| HEAT DISSIPATED          | 34,100 BTU/HR.          |                    |
| MAX. ROOM TEMPERATURE    | 90 F                    |                    |
| MAX. ROOM HUMIDITY       | 90%                     |                    |



*Figure 1-3. Cabling Diagram for Model 0 Univac File-Computer*

## MODEL 1

The Model 1 Central Computer is designed for operation as

- (a) a plugboard computer;
- (b) an internally-stored-program computer; or as
- (c) a combination plugboard/internally-stored-program computer.

### FUNCTIONAL DESCRIPTION

Plugboard Operation. When operated as a plugboard computer, Model 1 executes program Steps and Sub-Steps which are defined and carried out in much the same manner as those in the Model 0 Central Computer. However, as noted in Tables 1-2, 1-3, and 1-4, respectively, different processes and Sub-Steps are available and the operating storage for the Central Computer has a larger capacity.

Internally-Stored-Program Operation. When operated as an internally-stored-program computer, Model 1 executes Instruction Words. An Instruction Word is a 12-character computer instruction which is stored in the operating memory of the computer, generally in sequence with other instruction Words on the High-Speed Drum. An Instruction Word has the following format:

|     |     |     |                                  |
|-----|-----|-----|----------------------------------|
| U   | V   | W   | OP                               |
| xxx | xxx | xxx | xxx (x represents one character) |

where U, V, and W are usually storage addresses for  $V_1$ ,  $V_2$ , and R respectively; and OP is an operation code which specifies what the computer is to do in executing the instruction. When the Model 1 is used only as an internally-stored-program computer, the left two characters of OP specify one of the first 26 processes listed under Instruction Word Processes in Table 1-2. The right-most character in OP is a special character which extends or modifies the process specified by the other characters in OP. This special character has various values and is used to initiate the Instruction Word Sub-Instructions listed in Table 1-3. The storage location from which each Instruction Word is obtained is given by a Program Address Counter that is used to sequence internally stored programs.

Combination Plugboard/Internally-Stored-Program Operation. When Model 1 is used as a combination plugboard/internally-stored-program computer, it executes Program Steps or Instruction Words depending on whether Program Control obtains its instruction from the plugboard or the internally-stored program, respectively. Control is transferred from the internal program to the plugboard by executing a Transfer Control Instruction Word. The process-portion of the Operation Code in Transfer Control Instruction Words contains a number (51-98) which specifies the location on the plugboard (i.e., the Plugboard Step) from which the computer will obtain the next instruction to be executed. Thereafter,

Program Steps defined on the plugboard are executed rather than Instruction Words. Transfer of control from the plugboard to the internally-stored program is achieved by executing a NEXT INSTRUCTION Sub-Step on the plugboard. When this Sub-Step is carried out, plugboard-defined operations stop, and the next instruction executed is an Instruction Word. This Instruction Word's location is specified by the Program Address Counter.

Table 1-2  
MODEL 1  
PROCESSING

| PROGRAM STEP PROCESSES   | INSTRUCTION WORD PROCESSES   |
|--|--|
| ADD<br>ADD AND CHECK<br>SUBTRACT<br>SUBTRACT AND CHECK<br>MULTIPLY, STORE LOWER<br>MULTIPLY, STORE LOWER AND CHECK<br>MULTIPLY, STORE UPPER<br>MULTIPLY, STORE UPPER AND CHECK<br>DIVIDE, STORE QUOTIENT<br>DIVIDE, STORE QUOTIENT AND CHECK<br>DIVIDE, STORE REMAINDER<br>DIVIDE, STORE REMAINDER AND CHECK<br>COMPARE<br>ARITHMETIC TRANSFER<br>BUFFER TRANSFER<br>MASK TRANSFER<br>SUPPRESS LEFT ZERO<br>NORMALIZE<br>CHANNEL CLEAR | ADD<br>SUBTRACT<br>MULTIPLY, STORE LOWER<br>MULTIPLY, STORE UPPER<br>DIVIDE, STORE QUOTIENT<br>DIVIDE, STORE REMAINDER<br>ARITHMETIC TRANSFER<br>BUFFER TRANSFER<br>MASK TRANSFER<br>SUPPRESS LEFT ZERO<br>LEFT NORMALIZE<br>LOAD SHIFT<br>COMPARE<br>JUMP ON ZERO<br>JUMP ON PLUS<br>JUMP ON NEGATIVE<br>UNCONDITIONAL JUMP<br>CHANNEL CLEAR<br>LOAD ADR<br>TEST DEMAND STATION<br>DEMAND<br>TEST INCOMING CONTROL<br>CHANNEL SEARCH PROBE<br>SUBSTITUTE U<br>SUBSTITUTE V<br>SUBSTITUTE W<br>TRANSFER CONTROL TO PLUGBOARD (51-98) |

Table 1-3

MODEL 1 SUB-INSTRUCTIONS

| PROGRAM STEP<br>SUB-INSTRUCTIONS  | INSTRUCTION WORD<br>SUB-INSTRUCTIONS   |
|---|--|
| <p>CLEAR GENERAL STORAGE<br/>           BUFFER TO IGNORE<br/>           READ UNIT RECORD<br/>           WRITE UNIT RECORD<br/>           WRITE UNIT RECORD AND CHECK<br/>           CHANNEL SEARCH EQUAL<br/>           CHANNEL SEARCH UNEQUAL<br/>           CHANNEL SEARCH PROBE<br/>           CONDITION COMPARE<br/>           CLEAR BTB TO IGNORE<br/>           BRANCHING<br/>           FUNCTION DELAY<br/>           FUNCTION SEQUENCE<br/>           TEST DEMAND STATION<br/>           DEMAND IN<br/>           TRACK SWITCHING<br/>           STOP<br/>           NEXT INSTRUCTION (TRANSFER<br/>           CONTROL TO INTERNAL PROGRAM)</p> | <p>CLEAR GENERAL STORAGE<br/>           BUFFER TO IGNORE<br/>           READ UNIT RECORD<br/>           WRITE UNIT RECORD<br/>           WRITE UNIT RECORD AND CHECK<br/>           CHANNEL SEARCH EQUAL<br/>           CHANNEL SEARCH UNEQUAL<br/>           SPECIAL CHARACTER OUT<br/>           BREAKPOINT<br/>           STOP<br/>           SUPPRESS CHECK<br/>           SET CONDITIONAL STORAGE</p> |

Table 1-4

MODEL 1 OPERATING MEMORY

| TYPE  | NAME  |   |
|---|---|---|
| <p>HIGH-SPEED<br/>           DRUM</p>                     | <p>INTERMEDIATE STORAGE<br/>           20 INPUT/OUTPUT TRACKS<br/>           (TWO TRACKS FOR EACH<br/>           ADDRESS)<br/><br/>           87 FACTOR AND INTER-<br/>           MEDIATE STORAGE TRACKS</p>  | <p>120 CHARACTERS PER<br/>           TRACK. WORD AND<br/>           FIELD ADDRESSABLE.</p>  |
| <p>MAGNETIC<br/>           CORE<br/>           MEMORY</p> | <p>BLOCK TRANSFER BUFFER<br/><br/>           GENERAL STORAGE BUFFER</p>   | <p>120 CHARACTERS PER<br/>           BUFFER. WORD AND<br/>           FIELD ADDRESSABLE.</p>   |
| <p>REGISTER<br/>           MEMORY</p>                     | <p>REGISTER A<br/>           REGISTER B<br/>           REGISTER C<br/>           REGISTER D<br/>           CODE DISTRIBUTOR<br/>           GENERAL STORAGE ADDRESS<br/>           REGISTER<br/>           INSTRUCTION REVOLVER<br/>           PROGRAM ADDRESS COUNTER<br/>           SHIFT REVOLVER</p> | <p>12 CHARACTERS<br/>           12 CHARACTERS<br/>           12 CHARACTERS<br/>           12 CHARACTERS<br/>           1 CHARACTER<br/><br/>           7 CHARACTERS<br/>           12 CHARACTERS<br/>           3 CHARACTERS<br/>           12 CHARACTERS</p> |

Storage. The type, name, and capacity of each part of the operating storage in Model 1 Central Computers is listed in Table 1-4.

All locations in operating storage can be referred to by the U, V, and W portions of Instructions Words. Only the ten (pairs of) Input/Output Tracks (00-09) and the Factor Storage Tracks (11-12) are directly available to Program Steps via the plugboard addressing system. Program Steps in sequences initiated by Transfer Control Instruction Words, however, can access any track on the High-Speed Drum if the  $V_1$ ,  $V_2$ , or R ADDRESS hubs are appropriately patched.

All Model 1 General Storage Operations can be time-shared with the operation of the Central Computer. (See Section 2)

Input-Output System. The Model 1 Central Computer's in-out system is identical to that in the Model 0 Central Computer except that (a) each I/O Track location is actually a pair of tracks, and (b) up to 10 Univac File-Computer Input/Output Units can be included. In Model 1, at any given time at any of the 10 I/O Track locations, the computer is connected to one track of the pair, and the Univac File-Computer Input/Output Unit is connected to the other track of the pair. The computer and Univac File-Computer Input/Output Unit can thus time-share operations at the same I/O Track location. While the Univac File-Computer Input/Output Unit is loading or unloading one track, the computer can be loading or unloading the other. Track switching circuitry in the Univac File-Computer Input/Output Unit can be operated by the computer program to reverse the track assignments: the track formerly connected to the computer can be made available to the Univac File-Computer Input/Output Unit; and, what was the Univac File-Computer Input/Output Unit's track, can be made available to the computer. When the computer refers to an I/O Track location, it always communicates with the track (of the pair) to which it is connected at that time. When data transmissions to and/or from a Univac File-Computer Input/Output Unit occur, they take place to and/or from the track to which the Univac File-Computer Input/Output Unit is connected at that time. All data transmissions to and from each Univac File-Computer Input/Output Unit take place independently of the Central Computer.

## PHYSICAL DESCRIPTION

The Model 1 Central Computer (Figures 1-4, 1-5 and 1-6) consists of three cabinets: Program Control 1, Program Control 2, and Arithmetic. Table 1-5 lists the tentative installation requirements. Figure 1-7 is the cabling diagram for Model 1.

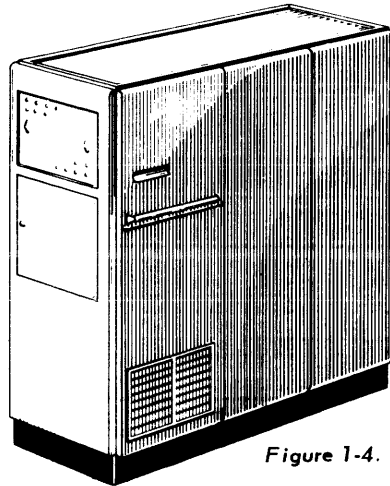

Figure 1-4.

Model 1 Program Control 1 Cabinet

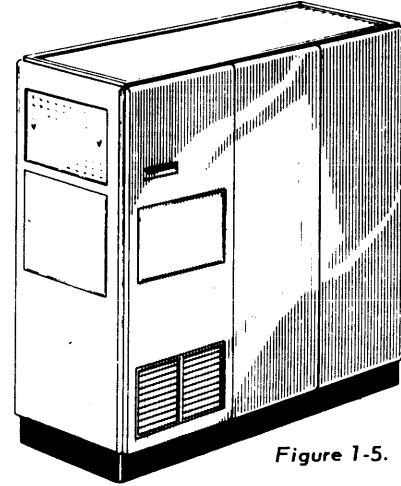

Figure 1-5.

Model 1 Program Control 2 Cabinet

Table 1-5  
TENTATIVE INSTALLATION REQUIREMENTS  
OF UNIVAC FILE-COMPUTER MODEL 1

|   | PROGRAM CONTROL CABINET #1                          | PROGRAM CONTROL CABINET #2       | ARITHMETIC CABINET               |
|---|---|----------------------------------|----------------------------------|
| SIZE AND WEIGHT:<br>WIDTH<br>LENGTH<br>HEIGHT<br>WEIGHT                                   | 30''<br>80''<br>71''<br>2000 LB.                    | 30''<br>80''<br>71''<br>2000 LB. | 30''<br>80''<br>71''<br>1420 LB. |
| CLEARANCE:<br>FRONT<br>BACK<br>RIGHT SIDE<br>LEFT SIDE                                    | 56''<br>30''<br>42''<br>42''                        | 56''<br>30''<br>42''<br>42''     | 56''<br>30''<br>42''<br>42''     |
| POWER DISSIPATION:  | 15.5 KW   |                                  |                                  |
| ELECTRIC SERVICE :<br>KVA<br>VOLTS<br>PHASE<br>MAX. LINE VARIATION                        | 20<br>208-240 VAC<br>3Ø-4 WIRE OR 1Ø-3 WIRE<br>± 5% |                                  |                                  |
| COOLING:<br>AIR CURRENT<br>HEAT DISSIPATED<br>MAX. ROOM TEMPERATURE<br>MAX. ROOM HUMIDITY | 3000 CFM<br>53,000 BTU/HR.<br>90 F<br>90 %          |                                  |                                  |

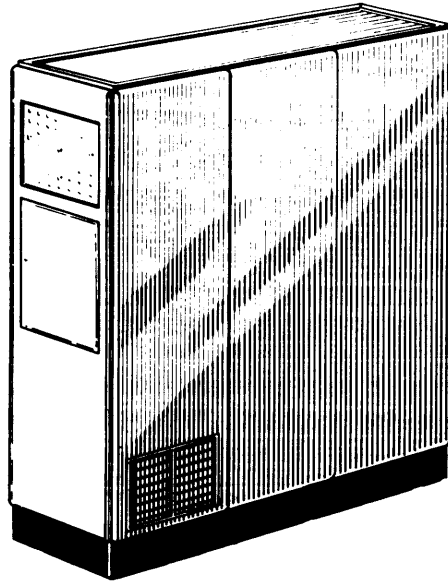

Figure 1-6. Model 1 Arithmetic Cabinet

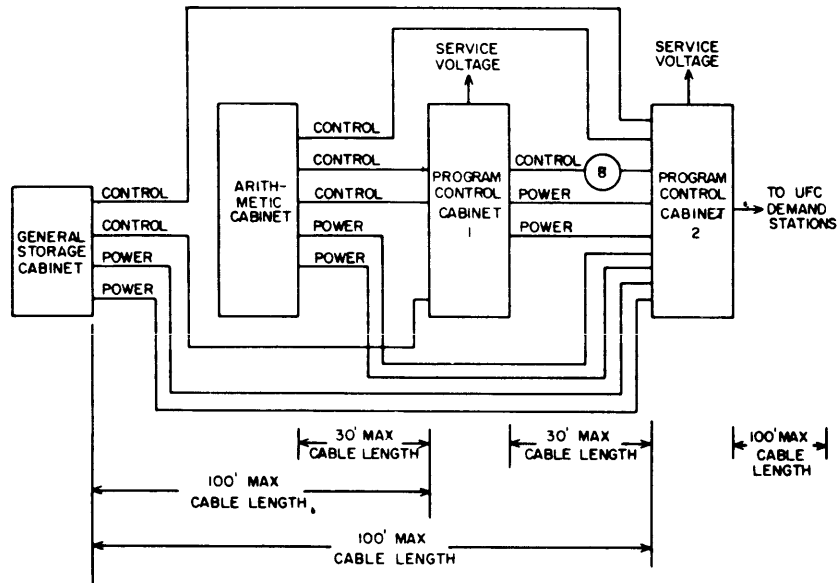

Figure 1-7. Cabling Diagram for Model 1 Univac File-Computer



## SECTION 2

# UNIVAC FILE-COMPUTER GENERAL STORAGE SYSTEMS

### FUNCTIONAL DESCRIPTION

Although the Model 0 and Model 1 General Storage Systems are radically different in certain respects, they have the following common design features:

1. A format for storing data which is similar (and, in many cases, identical) to the form of the business transaction. This basic, typical format is the individual Unit Record.
2. A capacity for storing internally thousands of Unit Records; the number of Unit Records and the length of each Unit Record being flexible, and determined by individual application requirements.
3. A random-access storage feature which permits either Univac File-Computer System to keep a current balance for a large number of items with high volume activity. Specifically, it allows
  - entry of input data into General Storage in the random sequence of its arrival; and
  - random-access to any Unit Record stored in General Storage either to obtain data from that Unit Record or to selectively alter data in that Unit Record.
4. A Search feature which enables General Storage to look for a certain Unit Record in accordance with a key or identifier, even though that Unit Record's address is not known.
5. Simultaneous operation with the Central Computer. Once given a time-sharing operation to perform, each type of General Storage carries that operation out independently of the Central Computer.

Table 2-1 is a brief comparison of Model 0 and Model 1 General Storage Systems.

## PHYSICAL DESCRIPTION

The Model 0 General Storage System (Figures 2-1 and 2-2) consists of two cabinets: General Storage and General Storage Extension. Table 2-2 lists the Model 0 General Storage System installation requirements. Figure 2-3 is the cabling diagram for the Model 0 General Storage System.

The Model 1 General Storage System (Figures 2-4 and 2-5) consists of two cabinets: General Storage Control and General Storage Drum. Table 2-3 lists the tentative Model 1 General Storage installation requirements. Figures 2-6 is the cabling diagram for the Model 1 General Storage System.

Table 2-1  
MODEL 0 AND MODEL 1 GENERAL STORAGE SYSTEMS

|                                  | MODEL 0  | MODEL 1   |
|----------------------------------|--|---|
| CAPACITY                         | FROM 1 UP TO 10 DRUMS<br>(180,000-1,800,000<br>CHARACTERS)   | FROM 1 UP TO 33 DRUMS<br>(180,000-5,940,000<br>CHARACTERS)  |
| UNIT RECORD<br>LENGTH            | FIXED (WIRED-IN) UNIT<br>RECORD LENGTH. CHOICE<br>OF 12, 15, 20, 24, 30, 40, 50,<br>60, 75, 100, OR 120 CHARAC-<br>TERS. COMPUTER CAN<br>REFER TO ENTIRE UR OR<br>TO ONE OF TWENTY FIELDS<br>OF DATA IN EACH UR. | VARIABLE UNIT RECORD<br>LENGTHS OF 12 N CHARAC-<br>TERS WHERE N = 1, 2, 3,<br>. . . 10.<br>UNIT RECORD LENGTH<br>DETERMINED BY A SWITCH<br>SETTING, OR BY A CON-<br>TROL BIT IN THE GENERAL<br>STORAGE ADDRESS. |
| AVERAGE ACCESS<br>TIME           | 34 MS  | 17 MS   |
| TIME-SHARED<br>OPERATIONS        | WRITE UNIT RECORD<br>READ UNIT RECORD<br>(A WRITE UNIT RECORD<br>AND CHECK OPERATION<br>CAN BE PROGRAMMED.)  | WRITE UNIT RECORD<br>WRITE UNIT RECORD AND<br>CHECK<br>READ UNIT RECORD<br>CHANNEL SEARCH EQUAL<br>CHANNEL SEARCH UNEQUAL<br>CLEAR GENERAL STORAGE<br>BUFFER TO IGNORE CODES                                    |
| OPERATIONS<br>NOT<br>TIME-SHARED | CHANNEL SEARCH EQUAL<br>CHANNEL SEARCH UN-<br>EQUAL  | ALL MODEL 1 GENERAL<br>STORAGE OPERATIONS<br>ARE TIME-SHARED.   |

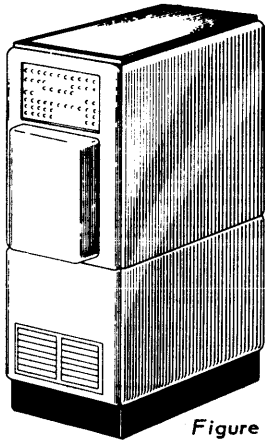

Figure 2-1.

Model 0 General Storage Cabinet

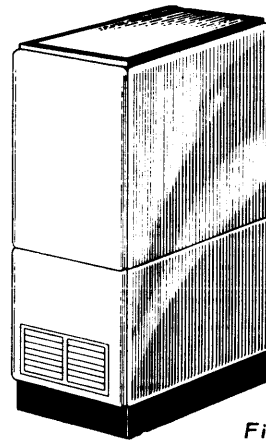

Figure 2-2.

Model 0 General Storage Extension Cabinet

Table 2-2

INSTALLATION REQUIREMENTS  
OF UNIVAC FILE-COMPUTER MODEL 0 GENERAL STORAGE SYSTEM

|  | GENERAL STORAGE<br>CABINET                           | GENERAL STORAGE<br>EXTENSION CABINET                 |
|--|--|--|
| SIZE AND WEIGHT:<br>WIDTH<br>LENGTH<br>HEIGHT<br>WEIGHT                                    | 30''<br>46''<br>71''<br>1232 LB.                     | 30''<br>46''<br>71''<br>1482 LB.                     |
| CLEARANCE:<br>FRONT<br>BACK<br>RIGHT SIDE<br>LEFT SIDE                                     | 56''<br>30''<br>36''<br>36''                         | 56''<br>30''<br>36''<br>36''                         |
| POWER DISSIPATION:   | 2KW  | 1.5 KW   |
| ELECTRIC SERVICE:<br>KVA<br>VOLTS<br>PHASE<br>MAX. LINE VARIATION                          | 3.0<br>208-240 VAC<br>3Ø-4 WIRE OR 1Ø-3 WIRE<br>+5 % | 2.0<br>208-240 VAC<br>3Ø-4 WIRE OR 1Ø-3 WIRE<br>+5 % |
| COOLING:<br>AIR CURRENT<br>HEAT DISSIPATION<br>MAX. ROOM TEMPERATURE<br>MAX. ROOM HUMIDITY | 360<br>6800 BTU/HR.<br>90 F<br>90 %                  | ---<br>5100 BTU/HR.<br>90 F<br>90 %                  |

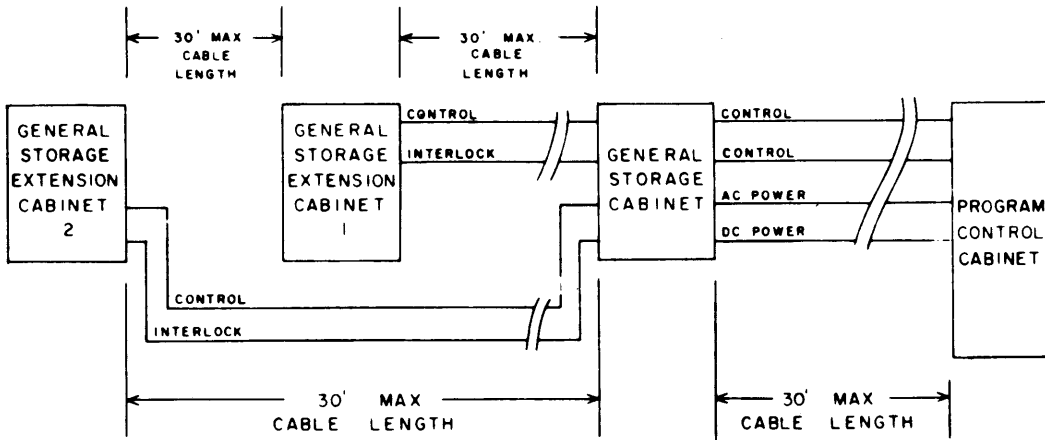

Figure 2-3. Cabling Diagram for Model 0 General Storage System

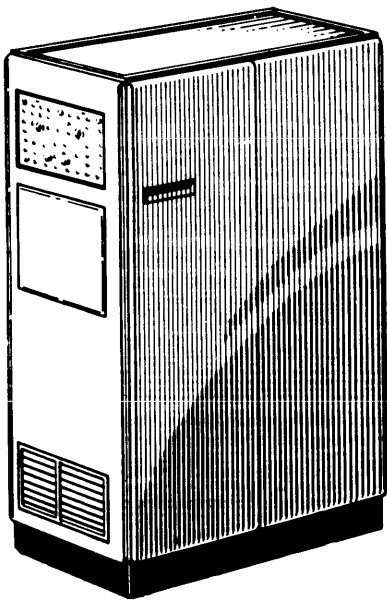

Figure 2-4.  
Model 1 General Storage Control Cabinet

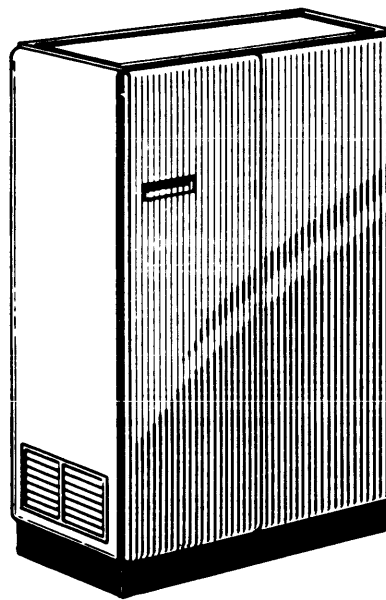

Figure 2-5.  
Univac File-Computer Model 1  
General Storage Drum Cabinet

Figure 2-6. Cabling Diagram for Model 1 General Storage System

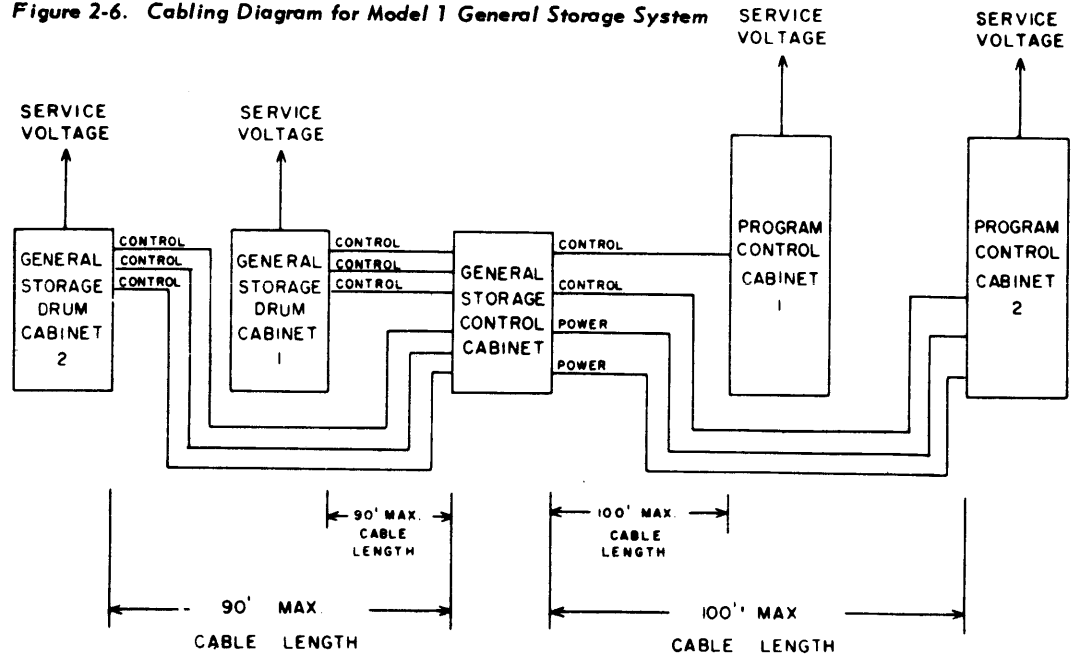

Table 2-3  
TENTATIVE INSTALLATION REQUIREMENTS  
OF MODEL 1 GENERAL STORAGE SYSTEM

|                       | GENERAL STORAGE CONTROL CABINET | GENERAL STORAGE DRUM CABINET |
|-----------------------|---------------------------------|------------------------------|
| SIZE AND WEIGHT:      |                                 |                              |
| WIDTH                 | 30"                             | 30"                          |
| LENGTH                | 61"                             | 46"                          |
| HEIGHT                | 71"                             | 71"                          |
| WEIGHT                | 1240 LB.                        | 1482 LB.                     |
| CLEARANCE:            |                                 |                              |
| FRONT                 | 56"                             | 56"                          |
| BACK                  | 30"                             | 30"                          |
| RIGHT SIDE            | 36"                             | 36"                          |
| LEFT SIDE             | 36"                             | 36"                          |
| POWER DISSIPATION:    | 4 KW                            | 1.5 KW                       |
| ELECTRIC SERVICE:     | 5                               | 2                            |
| KVA                   | 5                               | 2                            |
| VOLTS                 | 208-240 VAC                     |                              |
| PHASE                 | 3Ø-4 WIRE OR 1Ø-3 WIRE          |                              |
| MAX. LINE VARIATION   | ± 5 %                           |                              |
| COOLING:              |                                 |                              |
| AIR CURRENT           | 1000 CFM                        | ---                          |
| HEAT DISSIPATION      | 13,600 BTU/HR.                  | 5100 BTU/HR.                 |
| MAX. ROOM TEMPERATURE | 90 F                            | 90 F                         |
| MAX. ROOM HUMIDITY    | 90 %                            | 90 %                         |

## SECTION 3

# UNIVAC FILE-COMPUTER MODEL 1 CONSOLE SYSTEM

The Univac File-Computer Model 1 Console System consists of the Univac File-Computer Inquiry Typewriter and Univac File-Computer Console Control Panel.

### FUNCTIONAL DESCRIPTION

The Univac File-Computer Console System functions in two ways with the Univac File-Computer System: the inquiry typewriter communicates with the computer, and the console control panel monitors and alters computer program conditions.

#### Communication

With console operation selected on the typewriter control panel, the Univac File-Computer Inquiry Typewriter performs as a direct, two-way link between the operator and the Univac File-Computer System. On input, the operator can perform manual programming by entering instruction words into the computer. On output, the typewriter can type out the contents of any storage address in the Univac File-Computer System. In addition to these basic operations, the typewriter may be used to specify and initiate previously stored programs and plugboard routines.

#### Monitoring and Alteration

The console control panel indicators and controls permit monitoring of program runs and altering of program conditions. The indicators display the conditions existing in the Univac File-Computer system, while the controls permit altering of these conditions.

### PHYSICAL DESCRIPTION

The Univac File-Computer Console System (See figure 3-1) consists of a Remington Encoding/Decoding Electric Typewriter, a typewriter control panel, a console control panel, and a desk containing the control circuitry. Table 3-1 lists the tentative installation requirements. Figure 3-2 is the cabling diagram.

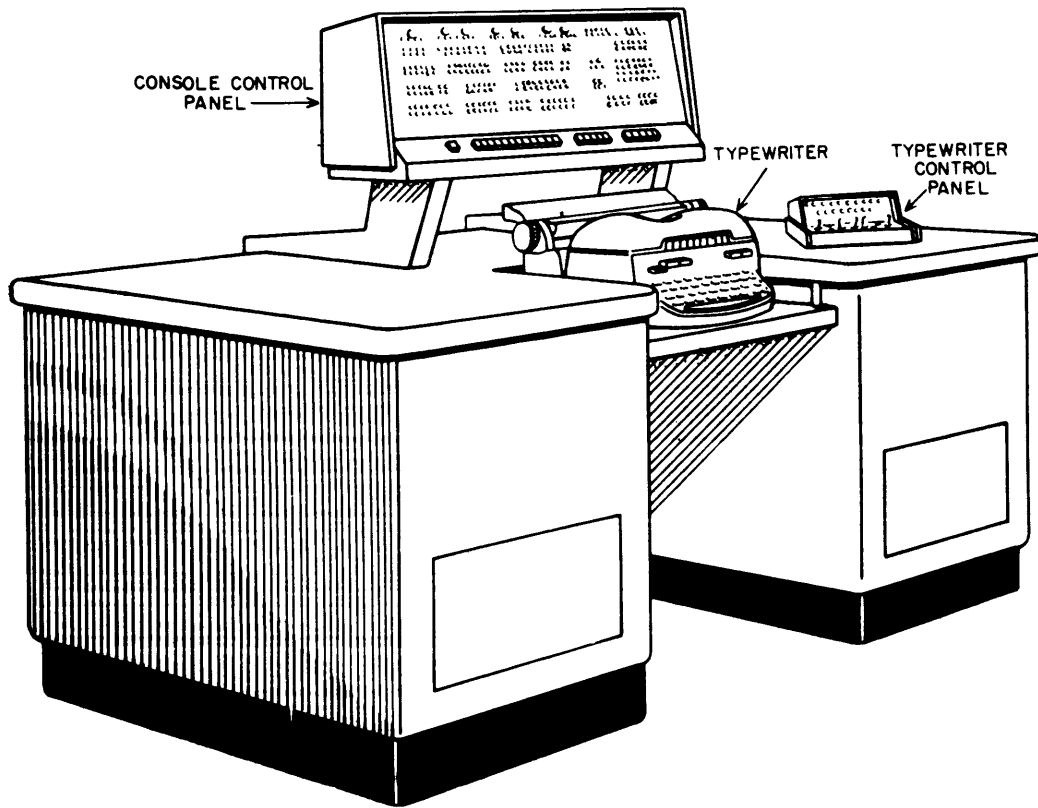

Figure 3-1. Univac File-Computer Model 1 Console System

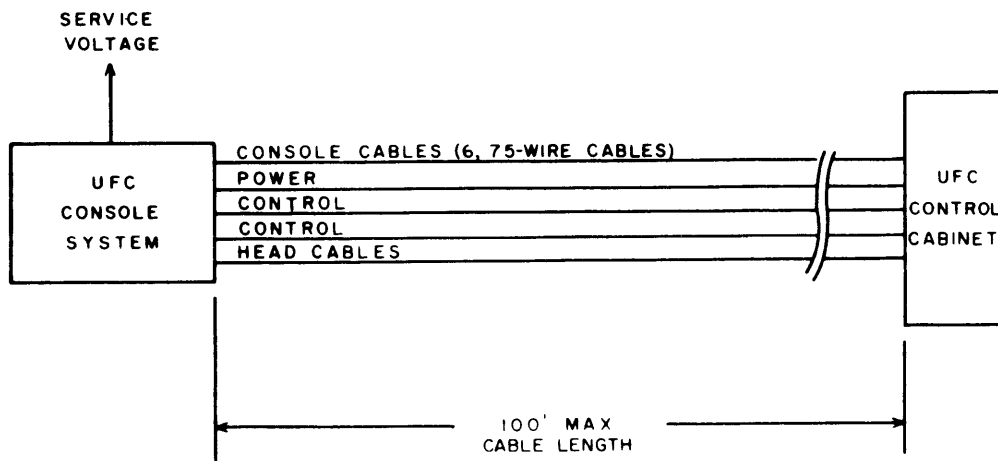

Figure 3-2. Cabling Diagram for Univac File-Computer Console System

Table 3-1  
 TENTATIVE INSTALLATION REQUIREMENTS  
 OF UNIVAC FILE-COMPUTER CONSOLE SYSTEM

|   |   |
|---|---|
| SIZE AND WEIGHT:<br>WIDTH<br>DEPTH<br>HEIGHT<br>WEIGHT                                    | 78''<br>36''<br>53''<br>600 LB.         |
| CLEARANCE:<br>FRONT<br>BACK<br>LEFT SIDE<br>RIGHT SIDE                                    | 38''<br>10''<br>0''<br>0''              |
| POWER DISSIPATION:  | 1.0 KW                                  |
| ELECTRIC SERVICE: *<br>KVA<br>VOLTS<br>PHASE<br>MAX. LINE VARIATION                       | 0.25<br>115 VAC<br>1<br>± 5 %           |
| COOLING:<br>AIR CURRENT<br>HEAT DISSIPATED<br>MAX. ROOM TEMPERATURE<br>MAX. ROOM HUMIDITY | 300 CFM<br>3400 BTU/HR.<br>90 F<br>90 % |

*\* Receives some power from Central Computer*



## SECTION 4

# UNIVAC FILE-COMPUTER INQUIRY TYPEWRITER

The Univac File-Computer Inquiry Typewriter is a Remington Encoding/Decoding Typewriter with the additional manual controls and electronic circuitry required to enable its use in on-line, two way communication with the Univac File-Computer. Operation of the typewriter is essentially manual; the only automatic operation available is an automatic output mode limited to repetitive output from one selected word address. No format control is provided.

### FUNCTIONAL DESCRIPTION

#### Coding

On input, the typewriter can encode all 64 Univac characters for transmission to the computer; on output, the typewriter can decode 44 characters plus space, tabulate and carriage return.

#### Operating Modes

In one output or input cycle, the typewriter can enter or type out a maximum of ten, 12-character words. During such a cycle, each word address must be selected manually on the typewriter control panel (only one word address can be selected at a time). For each word address selected, 12 characters are normally entered or typed out; the character addresses are selected in sequence automatically as characters are typed in or out. Indicator lights identify the selected word address and character address.

Input Mode. An input mode may take one of two possible forms: NORMAL or CONSOLE. In either form, the desired number of 12-character words (up to a maximum of ten) is typed in. A button is then pressed, informing the computer that the input operation has been completed, and that the input words are stored on the drum ready for use by the computer. When fewer than 12 characters are typed into a word address, the remaining character addresses are automatically filled with space codes.

If the NORMAL input mode has been selected, the computer program determines what is done with the input words. If the CONSOLE input mode has been selected, the input words themselves may be instruction words capable of controlling the computer in any desired manner. The NORMAL input mode, therefore, provides a means of manually entering information into the computer for use in a manner determined by the computer program. The CONSOLE mode, on the other hand, provides a means for manual programming of the computer.

Output Mode. Two types of output mode are possible: Manual and Automatic. The typewriter operates in the manual output mode unless the computer calls for an automatic output. In a manual output operation, each output word is selected manually by pressing the appropriate WORD ADDRESS button. As each word address is selected, the 12 characters stored at that word address are typed out in sequence at approximately 8.5 characters per second. Automatic output is available from only one word address: the one selected by the WORD ADDRESS button. When automatic output is requested by the computer, words stored successively in the selected word address are typed out automatically. As soon as one word has been typed out, a new word may be entered by the computer in the same word address, and is then typed out automatically.

#### Program Control and Modification

Computer-to I/O-control lines may be used to exercise control over typewriter operation. Signals generated in the computer and sent over these lines may request the following operating conditions: input mode, output mode, and automatic output mode. Signals sent to the computer over I/O-to-Computer control lines may be used to modify the computer program. These signals are generated when desired by setting one or more of four switches on the typewriter control panel.

#### PHYSICAL DESCRIPTION

The inquiry typewriter consists of a Remington Model 7CRP-1 Encoding/Decoding Electric Typewriter (less tape reader and tape punch), a typewriter control panel, and a desk containing the control circuitry (See figure 4-1). The console (if one is supplied) is mounted on the desk. Table 4-1 lists the estimated installation requirements, and Figure 4-2 illustrates the cabling required.

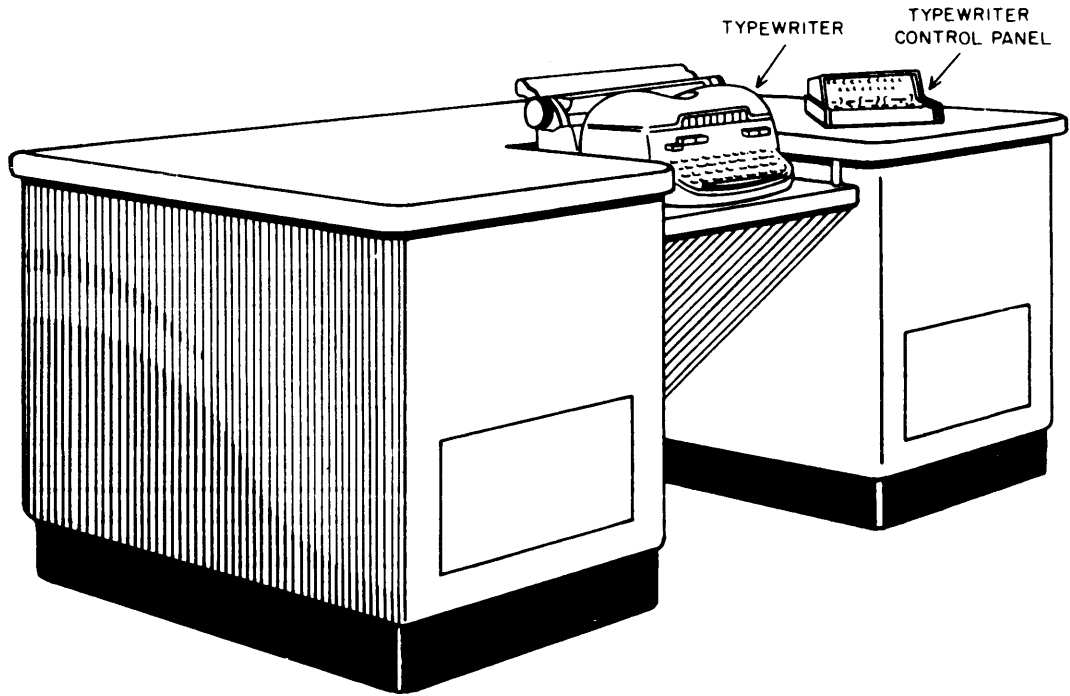

Figure 4-1 Type 1962 Inquiry Typewriter

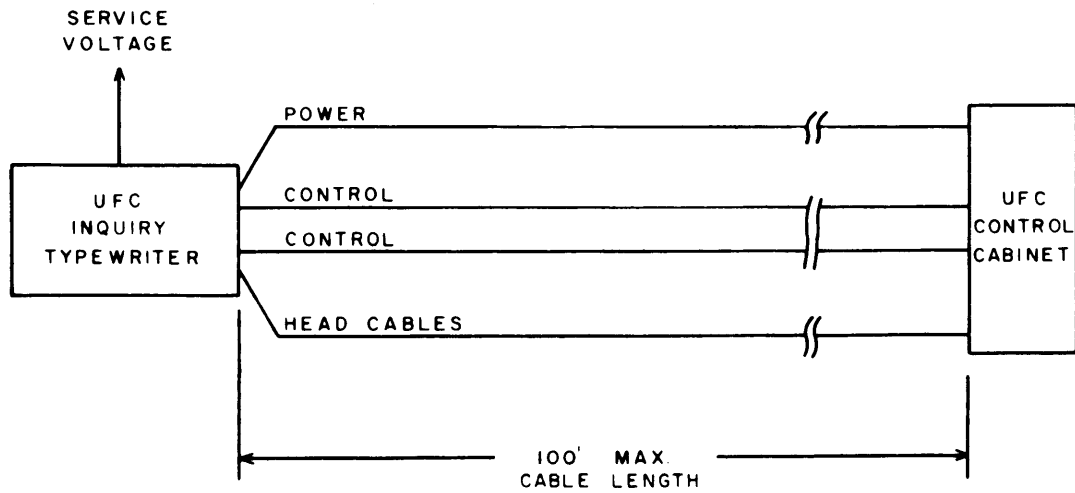

Figure 4-2. Cabling Diagram for Inquiry Typewriter

Table 4-1  
 TENTATIVE INSTALLATION REQUIREMENTS  
 OF UNIVAC FILE-COMPUTER INQUIRY TYPEWRITER

|   |   |
|---|---|
| SIZE AND WEIGHT:<br>WIDTH<br>DEPTH<br>HEIGHT<br>WEIGHT                                    | 78"<br>36"<br>30"<br>500 LB.            |
| CLEARANCE:<br>FRONT<br>BACK<br>LEFT SIDE<br>RIGHT SIDE                                    | 38"<br>10"<br>0"<br>0"                  |
| POWER DISSIPATION:  | 1 KW                                    |
| ELECTRIC SERVICE: *<br>KVA<br>VOLTS<br>PHASE<br>MAX. LINE VARIATION                       | 0.25<br>115 VAC<br>1<br>+5 %<br>—       |
| COOLING:<br>AIR CURRENT<br>HEAT DISSIPATED<br>MAX. ROOM TEMPERATURE<br>MAX. ROOM HUMIDITY | 300 CFM<br>3400 BTU/HR.<br>90 F<br>90 % |

\* Receives some power from Central Computer

## SECTION 5

# UNIVAC FILE-COMPUTER 90-COLUMN CARD SYSTEM

The Univac File-Computer 90-Column Card System is used as a Univac File-Computer tabulating card input unit, as a card output unit, or as a combined input-output unit. The System uses Remington Rand 90-Column tabulating card code. In the absence of prolonged computations (exceeding 235 millisecc of computer time per card), it processes 150 cards per minute.

### FUNCTIONAL DESCRIPTION

Used as an input device, the System reads information from cards and transmits it to the computer. Used as an output device, the System accepts output information from the computer and punches it into cards. Used as a combined input-output device, the System performs both functions together. Except during manual run-in and run-out operations, the System is controlled entirely by computer commands received via the Computer-to-IO control lines. Conversely, the System may send program-altering signals to the computer by way of the IO-to-Computer control lines.

However it is used, the System operates in a standard sequence that may be modified by control commands. Flexibility of control is further extended by plugboard routing of both data and control signals.

#### Standard Operation Sequence.

The System is provided with a magazine that feeds cards through a card-processing channel to a receiver. The channel picks the bottom card from the magazine, reads it, punches it, and deposits it in the receiver. Any of these processes may be without effect, depending on the program. In an input operation, for example, the card passes through the punch process unchanged.

## Repertoire of Control Commands

The System is able to execute any of the following three control commands: Trip, Skip and Sort.

Trip. A Trip pulse initiates a card cycle. During each card cycle (except during run-in and run-out) one new (input) card is taken in and one processed (output) card is produced. At the end of each card cycle, the card processor automatically stops unless another Trip pulse is received. The Trip pulse is received directly from the computer on one of the Computer-to-IO control lines.

Skip. A Skip pulse also initiates a card cycle, but it prevents the punch operation.

Sort. A Sort pulse isolates a selected card. Each processed (output) card is ordinarily deposited in what is called the "normal" receiver. If a Sort pulse is received, however, it is instead diverted to another receiver, called the "sort" receiver. This feature makes it possible to separate the cards into two categories on nearly any basis. Typically, it is used to separate records that require action.

## Plugboard Controls

The System includes a plugboard that permits format control, editing, and other miscellaneous control operations.

Format Control and Editing. Whenever information is read from a card, it passes through plugboard control. Plugboard patching can therefore rearrange the array of data from the card in any desired fashion and can insert unconditional signals wherever desired. Similar plugboard controls apply to data entering the card punch. Thus, the plugboard provides for format control and editing in every read or punch operation.

Miscellaneous Control Operations. The plugboard is provided with selector relays, delay devices, busses, etc. so that many varied logical combinations of control data may be implemented by plugboard patching.

All control lines between the computer and the system are connected to the System plugboard. The IO-to-Computer control lines bear any control signals that can be read from cards; the Computer-to-IO control lines may be patched directly to the TRIP, SKIP, SORT, and other entry hubs; or they may be connected to selectors etc. to provide more complicated control functions.

## PHYSICAL DESCRIPTION

The System consists of two separately housed sections: a type-4830 control cabinet and a type-4930 card processor. Overall dimensions and other installation specifications for both sections appear in Table 5-1 and Figure 4-3.

### Control Cabinet

The control cabinet (Figure 5-1) houses the connective circuitry (translators, registers, etc.) between the card processor and the main computer. It includes a display panel provided with lights to indicate errors, contents of registers, etc. A concealed maintenance panel provides ready access to controls used in maintenance operations. The control cabinet supports the plugboard and its receptacle.

### Card Processor

The card processor (Figure 5-2) reads, punches, and sorts cards in accord with signals from the control cabinet. It includes the feed magazine in which up to 600 cards may be entered and the two receivers ("normal" and "sort") into which they are finally deposited.

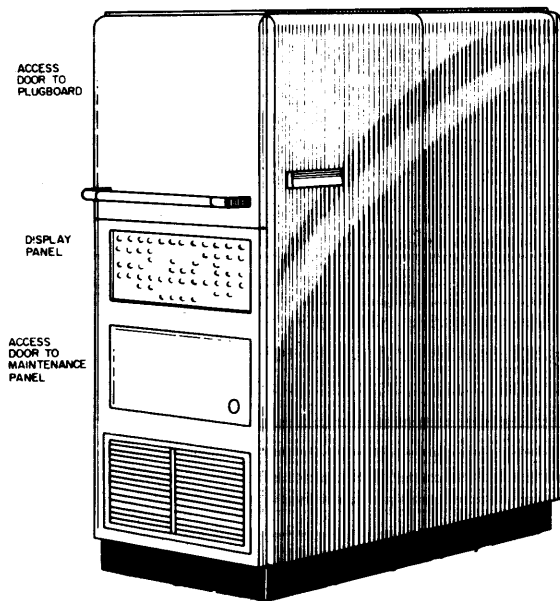

Figure 5-1.

Type 4830 Control Cabinet

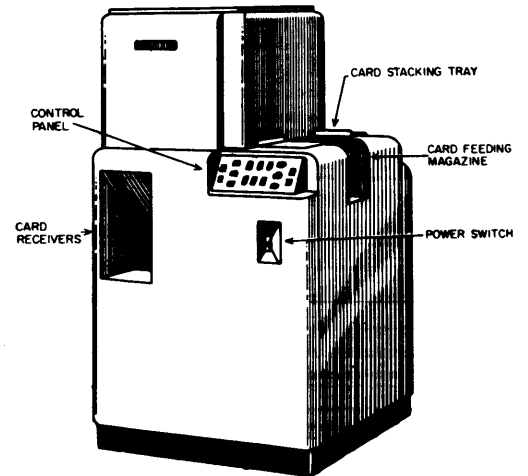

Figure 5-2.

Type 4930 Card Processor

Table 5-1

TENTATIVE INSTALLATION REQUIREMENTS  
OF UNIVAC FILE-COMPUTER 90-COLUMN CARD SYSTEM

|                           | CARD<br>PROCESSER      | CONTROL<br>CABINET |
|---------------------------|------------------------|--------------------|
| <b>SIZE AND WEIGHT:</b>   |                        |                    |
| WIDTH                     | 30"                    | 30"                |
| DEPTH                     | 32"                    | 48"                |
| HEIGHT                    | 65"                    | 71"                |
| WEIGHT                    | 1020 LB.               | 1220 LB.           |
| <b>CLEARANCE:</b>         |                        |                    |
| FRONT                     | 35"                    | 35"                |
| BACK                      | 30"                    | 30"                |
| RIGHT SIDE                | 36"                    | 42"                |
| LEFT SIDE                 | 34"                    | 42"                |
| <b>POWER DISSIPATION:</b> | 3 KW                   |                    |
| <b>ELECTRIC SERVICE:</b>  |                        |                    |
| KVA                       | 3.3                    |                    |
| VOLTS                     | 208-240 VAC            |                    |
| PHASE                     | 3Ø-4 WIRE OR 1Ø-3 WIRE |                    |
| MAX. LINE VARIATION       | ± 5 %                  |                    |
| <b>COOLING:</b>           |                        |                    |
| AIR CURRENT               | 240 CFM                |                    |
| HEAT DISSIPATED           | 10,200 BTU/HR.         |                    |
| MAX. ROOM TEMPERATURE     | 90 F                   |                    |
| MAX. ROOM HUMIDITY        | 90 %                   |                    |

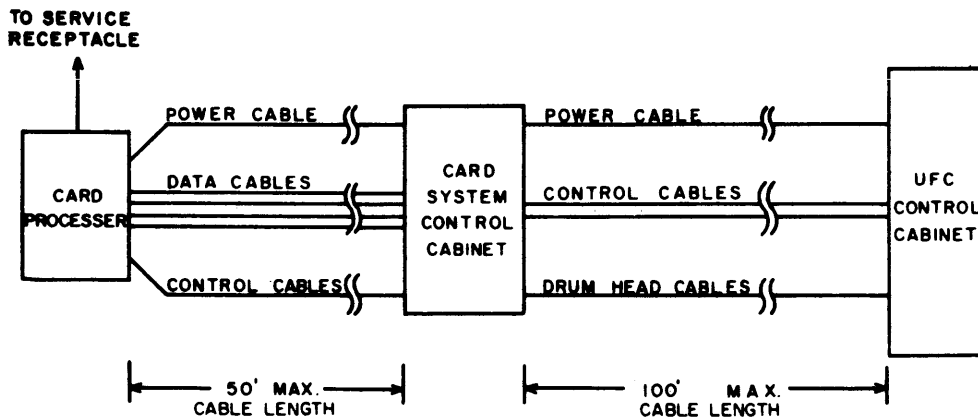

Figure 5-3. Cabling Diagram



## SECTION 6

# UNIVAC FILE-COMPUTER 90-COLUMN CARD SYSTEM (with post-read checking)

The Univac File-Computer 90-Column Card System (with Post-Read Checking) may be used as a Univac File-Computer tabulating card input unit, as a card output unit, or as a combined input-output unit. It is distinguished from the standard 90-Column Card System by added facilities that allow the results of every "read" or "punch" operation to be checked. This "post-read" checking consists of re-reading the processed card and checking it against comparison data stored in the System.

The System uses Remington Rand 90-Column tabulating card code. In the absence of prolonged computations (exceeding 235 millisecc of computer time per card), it processes 150 cards per minute.

### FUNCTIONAL DESCRIPTION

Used as an input device, the System reads information from cards and transmits it to the computer. Used as an output device, the System accepts output information from the computer and punches it into cards. Used as a combined input-output device, the System performs both functions together. Except during manual run-in and run-out operations, the System is controlled entirely by the computer commands received via the Computer-to-IO control lines. Conversely, the System may send program-altering signals to the computer by way of the IO-to-Computer control lines.

However it is used, the System operates in a standard sequence that may be modified by control commands. Flexibility of control is further extended by plugboard routing of data and control signals.

## Standard Operation Sequence

The System is provided with a magazine that feeds cards through a card-processing channel to a receiver. The channel picks the bottom card from the magazine, reads it, punches it, checks it, and deposits it in the receiver. Any of these processes may be without effect, depending on the program. In an input operation, for example, the card passes through the punch process unchanged. The check process tests the results of previous read and punch processes by sensing the information on the card and comparing it with a block of information stored in the System. (This "post-read" checking supplements parity checking.)

## Repertoire of Control Commands

The System is able to execute any of the following four control commands: Trip, Skip, No Check, and Sort.

Trip. A Trip pulse initiates a card cycle. During each card cycle (except during run-in and run-out) one new (input) card is taken in and one processed (output) card is produced. At the end of each card cycle, the card processor automatically stops unless another Trip pulse is received. A Trip pulse is produced whenever a Program Complete command is received on one of the Computer-to-IO control lines.

Skip. A Skip pulse prevents the punch operation.

No Check. A No Check pulse inhibits the check operation.

Sort. A Sort pulse initiates the isolation of a selected card. Each processed (output) card is ordinarily deposited in what is called the "normal" receiver. If a Sort pulse is received, however, it is instead directed to another receiver, called the "sort" receiver. This feature makes it possible to separate the cards into two categories on nearly any basis. Typically, it is used to separate records that require action.

## Plugboard Controls

The System includes a plugboard that permits format control, editing, check control, and other miscellaneous control operations.

Format Control and Editing. Whenever information is read from a card, it passes through plugboard control. Plugboard patching can therefore rearrange the array of data from the

card in any desired fashion and can insert unconditional signals wherever desired. Similar plugboard controls apply to date entering the card punch. Thus the plugboard provides for format control and editing in every read or punch operation.

Check Control. The check process need not apply to all of the card. Plugboard patching determines what parts (if any) of the card are checked.

Miscellaneous Control Operations. The plugboard is provided with selector relays, "and" ("combine") gates, delay devices, busses, etc. so that many varied logical combinations of control data may be implemented by plugboard patching.

One of the Computer-to-IO control lines is reserved for Trip pulses. All other control lines between the computer and the System are connected to the System plugboard. The IO-to-Computer control lines bear any control signals that can be read from cards; the Computer-to-IO control lines may be patched directly to the SORT, SKIP, NO CHECK, and other exit hubs; or they may be connected to selectors etc. to provide more complex control functions.

## PHYSICAL DESCRIPTION

The Univac File-Computer 90-Column Card System (with Post-Read Checking) consists of two separately housed sections: a type-4831 control cabinet and a type-4931 card processor. Overall dimensions and other installation specifications for both sections appear in Table 6-1 and Figure 6-3.

### Control Cabinet

The control cabinet (Figure 6-1) houses the connective circuitry (translators, registers, etc.) between the card processor and the main computer. It includes a display panel provided with lights to indicate errors, contents of registers, etc. A concealed maintenance panel provides ready access to controls used in maintenance operations. The cabinet also supports the plugboard and its receptacle.

### Card Processor

The card processor (Figure 6-2) reads, punches, and sorts cards in accord with signals from the control cabinet. It includes the feed magazine in which up to 600 cards may be entered and the two receivers ("normal" and "sort") into which they are finally deposited.

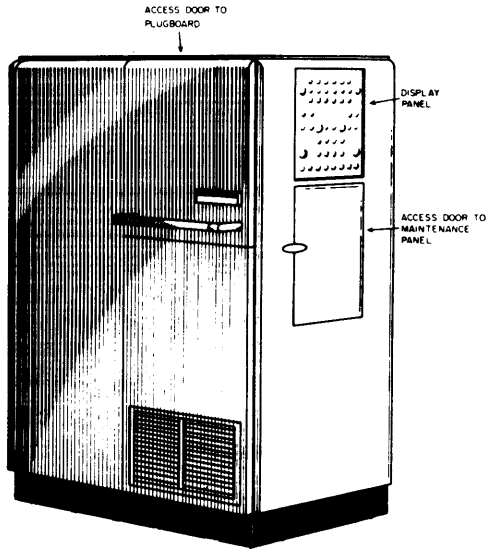

Figure 6-1. Type 4831 Control Cabinet

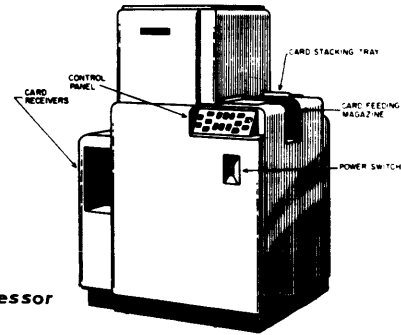

Figure 6-2. Type 4831 Card Processor

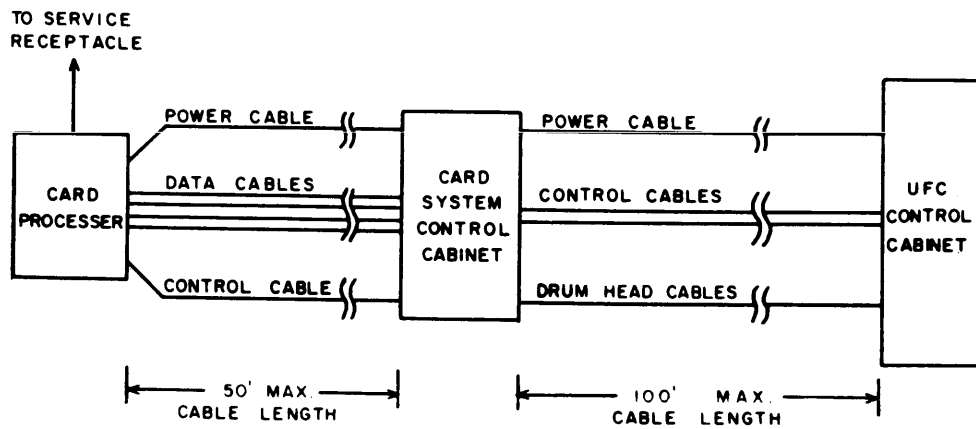

Figure 6-3. Cabling Diagram

Table 6-1  
 TENTATIVE INSTALLATION REQUIREMENTS  
 OF UNIVAC FILE-COMPUTER 90-COLUMN CARD SYSTEM  
 (WITH POST-READ CHECKING)

|   | CARD<br>PROCESSER                                    | CONTROL<br>CABINET                |
|---|--|-----------------------------------|
| SIZE AND WEIGHT:<br>WIDTH<br>DEPTH<br>HEIGHT<br>WEIGHT                                    | 40"<br>30"<br>64"<br>1180 LB.                        | 30"<br>60-1/2"<br>71"<br>1560 LB. |
| CLEARANCE:<br>FRONT<br>BACK<br>RIGHT SIDE<br>LEFT SIDE                                    | 24"<br>24"<br>24"<br>24"                             | 30"<br>30"<br>42"<br>42"          |
| POWER DISSIPATION:  | 3 KW   |                                   |
| ELECTRIC SERVICE:<br>KVA<br>VOLTS<br>PHASE<br>MAX. LINE VARIATION                         | 4.8<br>208-240 VAC<br>3Ø-4 WIRE OR 1Ø-3 WIRE<br>± 5% |                                   |
| COOLING:<br>AIR CURRENT<br>HEAT DISSIPATED<br>MAX. ROOM TEMPERATURE<br>MAX. ROOM HUMIDITY | 240 CFM<br>10,200 BTU/HR.<br>90 F<br>90 %            |                                   |

## SECTION 7

### UNIVAC FILE-COMPUTER 80-COLUMN CARD SYSTEM (bull)

The Univac File-Computer 80-Column Card System (Bull) is used as a Univac File-Computer tabulating card input unit, as a card output unit, or as a combined input-output unit. It can operate simultaneously on two stacks of cards, punching output data into one stack and reading input data from either or both stacks. Processing of the two stacks is synchronized so that corresponding cards from each stack are processed simultaneously.

Except during manual run-in and run-out, the System is controlled entirely by computer commands via the Computer-to-IO control lines. Conversely, the System may send program-altering signals to the computer by way of IO-to-Computer control lines.

The System uses standard 80-column card code and processes either or both stacks at 150 cards per minute in the absence of computational delays.

#### FUNCTIONAL DESCRIPTION

Operation of the System consists of a few basic processes performed in a standard sequence that can be modified by control commands and plugboard patching. The many possible types of operation are divided into two broad categories called Mode I and Mode II.

#### Basic Processes

The basic processes that the System can perform are reading, punching, checking, and re-reading. The check process tests the results of previous read and punch processes by sensing the information on the card and comparing it with a block of information stored in the System. (This "post-read" checking is independent of parity checking, which is performed elsewhere.) "Re-reading" refers to an auxiliary reading process that is not used to produce computer input data.

## Standard Operation Sequence

The System is provided with two card feeding magazines, each of which feeds cards through a separate channel to a corresponding receiver. The channels are called the "punch" and "read" channels, respectively.

The two channels work simultaneously, each performing three, parallel, sequenced operations. The punch channel picks the bottom card from the punch magazine, reads it, punches it, checks it, and deposits it in the punch receiver. The read channel picks the bottom card from the read magazine, reads it, checks it, re-reads it, and deposits it in the read receiver. Operation of the two channels is synchronized so that the processing of corresponding cards from the two stacks may be co-ordinated.

## Repertoire of Control Commands

The System performs any of the following seven commands that normally come from the computer via the Computer-to-IO control lines.

Program Complete. In passing from the magazine to the receiver of either channel, a card occupies a sequence of four intermediate stations. Each Program Complete command initiates a card cycle---a mechanical process that advances the cards in both channels to the next station. At the end of each card cycle, the card processor automatically stops unless another Program Complete command is received. Five Program Complete commands are required to carry one card from each feed magazine to the corresponding receiver. The Program Complete command is normally sufficient to advance the cards from every station but two: the first station in each channel requires an additional "conditioning" signal to enable it to respond to a Program Complete signal.

Trip Read Feed. A Trip Read Feed command conditions the first station in the read channel so that it can respond to the next (or simultaneous) Program Complete signal by passing the card from the first station to the second.

Trip Punch Feed. A Trip Punch Feed command similarly conditions the first station in the punch channel so that it can respond properly to a Program Complete.

Skip. A Skip command prevents the punch operation.

Read Non-Check. A Read Non-Check command inhibits the check operation in the read channel.

Punch Non-Check. A Punch Non-Check command similarly inhibits the check operation in the punch channel.

Light Indicator. A Light Indicator command causes a particular lamp on the display panel to light. This lamp indicates the presence of some programmer-selected condition (such as "end of run") in the computer.

### Plugboard Controls

The System includes a plugboard that permits format control, editing, check control, and other miscellaneous logical operations.

Format Control and Editing. Whenever information is read from a card, it passes through plugboard control. Plugboard patching can therefore rearrange the array of data from the card in any desired fashion and can insert unconditional signals wherever desired. Similar plugboard controls apply to data entering the card punch. Thus the plugboard provides for format control and editing in every read or punch operation.

Check Control. The check process need not apply to all of the card. Plugboard patching determines what parts (if any) of the card are checked.

Miscellaneous Control Operations. The plugboard is provided with selector relays, delay devices, busses, etc. so that many varied combinations of control data may be implemented by plugboard patching.

All control lines between the computer and the System are connected to the System plugboard. The Computer-to-IO control lines entry hubs may be patched directly to the command hubs (PROGRAM COMPLETE, TRIP READ FEED, etc.) and other exit hubs, or they may be connected through selectors, etc. to provide more complex control functions.

The IO-to-Computer control lines may bear any control signals that can be read from cards in either channel. They may also carry four control signals that mark the beginning and end of the file in each channel.

### Mode I Operation

Mode I operation is any input-output operation in which all computer input data come from the read channel and all output data are sent to the punch channel. The cards entered in the punch feeding magazine may be either blank or prepunched. The read operation in the



punch channel is not used (except perhaps, for control signals). Mode I operation allows 400 millisecc of computer time per card and 150 cards per minute with ("post-read") checking in both channels.

#### Mode II Operation

Mode II operation is any input-output operation in which input data are read from cards in the punch channel and the corresponding output data are subsequently punched on the same respective cards. The read channel may be (1) unused, (2) used simultaneously to enter unrelated data in the computer, or (3) used to provide computer input data augmenting that read in the punch channel. In the last case, the reading is synchronized so that data from two corresponding cards---one in each channel---may enter the computer as two distinct input blocks or may be merged to form a single input block. At 150 cards per minute with "post-read" checking in both channels, the computer time per card is 80 millisecc in the punch channel and 320 millisecc in the read channel.

#### PHYSICAL DESCRIPTION

The Univac File-Computer 80-Column Card System (Bull) consists of two separately housed sections: a type-4840 control cabinet and a type-4940 card processor. Overall dimensions and other installation specifications appear in Table 7-1 and Figure 7-3.

#### Control Cabinet

The control cabinet (Figure 7-1) houses the connective circuitry (translators, registers, etc.) between the card processor and the main computer. It includes a display panel provided with lights to indicate errors, contents of registers, etc. A concealed maintenance panel provides ready access to controls used in maintenance operations. The cabinet also supports the plugboard and its receptacle.

#### Card Processor

The card processor (Figure 7-2) reads, punches, and checks cards in two channels in accord with signals from the control section. It includes the two feed magazines, which can hold stacks of up to 800 cards each; and two receivers, which are at the rear of the processor.

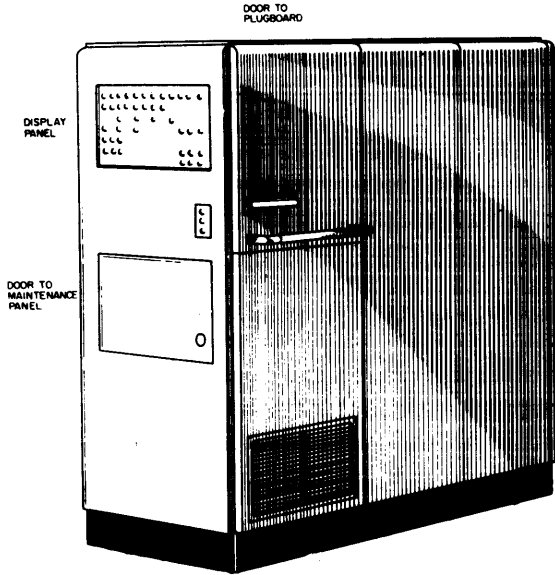

Figure 7-1. Type 4840 Control Cabinet

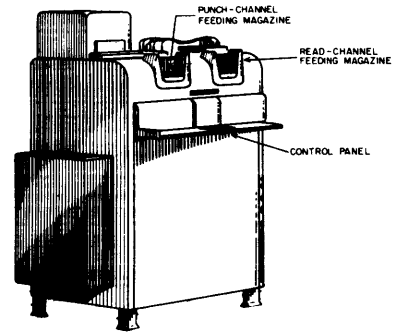

Figure 7-2. Type 4940 Card Processor

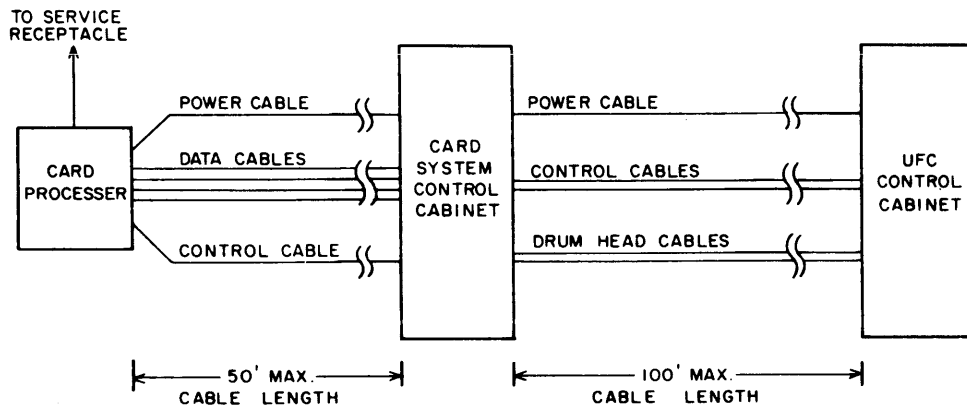

Figure 7-3. Cabling Diagram

**Table 7-1**  
**TENTATIVE INSTALLATION REQUIREMENTS**  
**OF UNIVAC FILE-COMPUTER 80-COLUMN CARD SYSTEM**

|  | CARD<br>PROCESSOR                                    | CONTROL<br>CABINET            |
|--|--|-------------------------------|
| <b>SIZE AND WEIGHT:</b><br>WIDTH<br>DEPTH<br>HEIGHT<br>WEIGHT                                    | 30"<br>34"<br>49"<br>1000 LB.                        | 30"<br>80"<br>71"<br>1220 LB. |
| <b>CLEARANCE:</b><br>FRONT<br>BACK<br>RIGHT SIDE<br>LEFT SIDE                                    | 30"<br>24"<br>24"<br>24"                             | 42"<br>30"<br>33-1/2"<br>42"  |
| <b>POWER DISSIPATION:</b>  | 3 KW   |                               |
| <b>ELECTRIC SERVICE:</b><br>KVA<br>VOLTS<br>PHASE<br>MAX. LINE VARIATION                         | 4.8<br>208-240 VAC<br>3Ø-4 WIRE OR 1Ø-3 WIRE<br>± 5% |                               |
| <b>COOLING:</b><br>AIR CURRENT<br>HEAT DISSIPATED<br>MAX. ROOM TEMPERATURE<br>MAX. ROOM HUMIDITY | 1100 CFM<br>10,200 BTU/HR.<br>90 F<br>90%            |                               |

## SECTION 8

# UNIVAC FILE-COMPUTER MAGNETIC TAPE UNIT

### FUNCTIONAL DESCRIPTION

#### Capabilities

The Univac File-Computer Magnetic Tape Unit (Figure 8-1) is a multi-purpose magnetic tape device which can be included in any Univac File-Computer installation.

Its fundamental purpose is to read, record and variously position mylar magnetic tape.

In the Univac File-Computer System, three uses are made of this equipment:

1. It is an Input/Output Unit for the Computer;
2. It is in integral part of the Sort-Collate System; four of these Tape Units and a Sort-Collate Unit form the Sort-Collate System;
3. It is the data source for off-line operation of the High-Speed Printer.

As an Input/Output Unit, the Univac File-Computer Magnetic Tape Unit is an on-line device and its operations are controlled by a computer program. However, except during intervals in which control information is exchanged, the computer and Univac File-Computer Magnetic Tape Unit operate independently.

As a part of the Sort-Collate System, the Univac File-Computer Magnetic Tape Unit is entirely controlled by a Sort-Collate program during the actual file processing operations of that system. Circuitry is provided however, so that in all collating operations of that system, except the sort and sequence checking operations, the Sort-Collate program can release control of the Univac File-Computer Magnetic Tape Units and allow the computer to operate them as Input/Output equipments. The purpose of this feature, called Computer Alert, is to permit collating and file-updating operations to be performed in a single pass through the tape data. Upon completion of the updating routine the computer returns control of the Univac File-Computer Magnetic Tape Units to the Sort-Collate System. If the Sort-Collate program is so plugged, the collating operation continues automatically thereafter.

Use of the Univac File-Computer Magnetic Tape Unit as a data source for High-Speed Printer operation is an off-line activity for both the Univac File-Computer Magnetic Tape Unit and the High-Speed Printer.

Controls on the Univac File-Computer Magnetic Tape Unit permit manual operation of the tape handler to position tape. These controls can be operated independently of the computer, Sort-Collate System, or High-Speed Printer.

In this section, only the computer input-output functions of the Univac File-Computer Magnetic Tape Unit are discussed. See Sections 9 and 10, respectively, for operation of this equipment in the Sort-Collate and High-Speed Printer Systems.

The Univac File-Computer Magnetic Tape Unit itself is designed for use only in a Univac File-Computer System. However, 1 1/2 mil base mylar tapes prepared on this equipment in compatible format and recording density can be used on other mylar tape-processing Univac equipment, and vice-versa.

## Medium

General. Mylar magnetic tape is the medium employed in this device. The mylar base is oxide coated and data is recorded by magnetizing minute spots on this coated surface. Each spot is given one or the other of two polarities and accordingly is thought of as storing a "1" or a "0". Reading is accomplished by sensing these recorded spots.

Data is recorded and read a line at a time. One standard 7-bit computer character is stored on each line; and 120 consecutive lines (or characters form a blockette. Blockettes are 0.86" in length and are separated by 0.5" of 1" blank spaces. The blockette is the tape equipment's unit of format.

The principal programming unit is the File. Files are composed of a group of contiguous items, each of which is a collection of consecutive characters that uniquely defines a major file entry. A blockette may contain several Items; it may be an Item itself; or several blockettes may be required for an Item. Items are physically recorded in blockette format, but the number and sequence of characters they contain is determined by the recording program on the basis of the File being recorded.

Associated with each blockette is a group of identifiers which are copies of the various sets of data stored in the blockette. These identifiers can be used by the computer program to locate tape data during tape search operations.

**Tape Specifications:**

**Width:** 1/2''  
**Base:** 1 1/2 mil mylar  
**Recording Density:** 139 lines/inch (Univac systems employing the standard Univac 128 lines/inch recording density can read this density; conversely, a recording density of 128 lines/inch can be read by the Univac File-Computer Magnetic Tape Unit)  
**Standard Length:** 2500'

**Number of Blockettes/Reel:**

| Blockette Spacing | 2500' Length |
|-------------------|--------------|
| 0.5''             | 17,640       |
| 1''               | 12,600       |

**Mylar Tape Handler Specifications: (Potter Tape Unit, Model 3232)**

**Tape Transport Speed;** 75''/sec  
**Read/Write Rate:** 10,400 characters/sec (single blockette type of operation)  
**Start Time, Write:** (including acceleration and blockette spacing time)  
0.5'' blockette spacing: 7ms  
1'' blockette spacing: 13ms  
**Stop and Lockout Time:** 10 ms (This includes deceleration time and the lockout or reverse direction time. The minimum time between operations involving tape movement is thus 10 ms)  
**Start Read Times:** (assuming previous stop lockout delay has elapsed)

| Operation                                  | 0.5" Blockette Spacing | 1" Blockette Spac. |
|--|------------------------|--------------------|
| Read Forward after previous Read Forward   | 7 ms                   | 13 ms              |
| Read Forward after previous Read Backward  | 2-3 ms                 | 2-3 ms             |
| Read Backward after previous Read Forward  | 2-3 ms                 | 2-3 ms             |
| Read Backward after previous Read Backward | 7 ms                   | 13 ms              |

Blockette Read/Write Time: 11.5 ms (does not include start-stop time listed above)

Wind and Rewind Rates: 75"/sec; time required is approximately 9 1/2 minutes for 3600' length, and 6 1/2 minutes for 2500' length. Checking performed during Rewind operations.

Bad Spot Detection: Bad tape areas are photoelectrically sensed in both forward and backward direction. Compatible Bad Spot Logic.

Reel Changing: By prethreaded, detachable tape leader.

I/O Instructions. The Univac File-Computer Magnetic Tape Unit can execute the 13 I/O instructions listed below.

These I/O Instructions are sent to the Univac File-Computer Magnetic Tape Unit's Demand Station via the Computer-to-IO control lines when the Univac File-Computer Magnetic Tape Unit is placed "on demand".

Only one I/O Instruction can be given the Univac File-Computer Magnetic Tape Unit at a time.

|                        |                       |
|------------------------|-----------------------|
| WRITE                  | TRANSFER BUFFER       |
| WRITE & CHECK          | CONTENTS TO I/O TRACK |
| READ FORWARD           | TRANSFER I/O TRACK    |
| READ BACKWARD          | CONTENTS TO BUFFER    |
| SEARCH FORWARD EQUAL   | WIND FORWARD          |
| SEARCH BACKWARD EQUAL  | REWIND                |
| SEARCH FORWARD = or >  | REWIND WITH INTERLOCK |
| SEARCH BACKWARD = or < |                       |

Write, Write and Check, and Read operations are one-blockette operations; i.e., they process 120 characters and the tape stops. Search and Winding operations involve continuous tape movement. No tape movement is involved in Buffer-I/O Track transfers.

Write operations are always performed with the tape moving in the forward direction. Since data ahead of the data being recorded is erased, tape data cannot be selectively altered. Writing should, therefore, be initiated from the beginning of the tape or from the position where the last writing operation terminated.

Read, Search, and Winding operations can be performed in both the forward and backward direction of tape movement.

Write operations imply (a) that the data to be recorded has been previously loaded by the computer program on the I/O Track connected to the computer; and, in Model 1 systems, (b) that a subsequent track switching operation was performed, to make that data available to the Univac File-Computer Magnetic Tape Unit for recording. Similarly, Search operations imply (a) that an identifier has previously been loaded on the I/O Track connected to the computer; and, in Model 1 systems, (b) that track switching is subsequently programmed to make the identifier available to the Univac File-Computer Magnetic Tape Unit.

At the end of each Read Instruction, the I/O Track connected to the Univac File-Computer Magnetic Tape Unit will be loaded with the blockette of data read. Similarly, in Search operations during which a "find" occurs, the blockette "found" will be loaded on that I/O Track. If no match ("find") between the identifier and any blockette in a File is obtained, the I/O Track will not contain any data from the Search operation.

After all Write, Read, and Search ("find") operations, the tape is positioned immediately after the blockette which is written, read, or "found". After Search (no "find") the tape is positioned immediately after the blockette in which an End of File or End of Data is detected.



Each time an I/O Instruction is received, the Magnetic Tape Unit takes itself "off demand". If the Magnetic Tape Unit is placed "on demand" and no I/O Instruction is subsequently given it, the Magnetic Tape Unit remains "on demand" until another I/O Unit is placed "on demand".

#### Control Information for the Computer

The following seven items of data, resulting from operations of the Univac File-Computer Magnetic Tape Unit, are sent to the computer during Demand In sequences. The computer uses this information for program variance.

SEARCH, FIND =  
SEARCH, FIND > or < (> for forward search; < for backward search)  
\*END OF FILE  
\*END OF DATA  
END OF BLOCKETTE COUNT  
BEGINNING OF TAPE  
END OF TAPE

In Model 1 Univac File Computer the above control information is sent to the computer via the High-Speed IO-to-Computer control lines W, X, Y, and Z. A Pinboard on the Magnetic Tape Unit Control Panel allows each of these seven control conditions to be defined in terms of W, X, Y, Z, or combination of these lines. In Model 0 Univac File-Computer systems, seven relay-operated (low-speed) IO-to-Computer control lines (a-g) are used for this purpose. They also can be plugged as desired on the Pinboard. The relay-operated IO-to-Computer control lines are also available in Model 1 systems for defining certain of the less critical conditions in the Magnetic Tape Unit, if the controlling computer program is plugboard-defined, and it is necessary or convenient to use them.

#### Checking Features

Parity Check on each character processed.  
120-Count Check on each blockette sensed.  
Write and Check I/O Instruction.  
Check during Rewind.

---

\* Each of the seven types of control information is detected automatically by circuitry in the Univac File-Computer Magnetic Tape Units. End of File and End of Data are code words which must be stored on the tape together with the actual data. The other control information does not require coding on the tape.

If a check detects an error, the processing of the current blockette is repeated; if the second attempt fails, a third and final try is automatically made. Provision is thus made for automatic recovery from most tape failures due to minor or temporary tape imperfections or possible momentary equipment failure.

## PHYSICAL DESCRIPTION

The Univac File-Computer Magnetic Tape Unit (See Figure 8-1) is housed in a single cabinet. The cabinet is mounted on casters to facilitate placement of the Univac File-Computer Magnetic Tape Unit in the various configurations noted above.

The principal components of this cabinet are:

- Mylar Tape Handler
- 120-Character Buffer
- Comparator (single-character)
- Demand Station
- Pinboard
- Associated control circuitry.

Table 8-1 lists the tentative installation requirements for each Univac File-Computer Magnetic Tape Unit. Figure 8-2 illustrates the cable connections required when this equipment is used as an I/O Unit in Univac File-Computer installations. See Figures 9-2, 9-3, and Figure 10-4, respectively, for cable connections required in operation of the Univac File-Computer Magnetic Tape Units in the Sort-Collate and High-Speed Printer Systems.

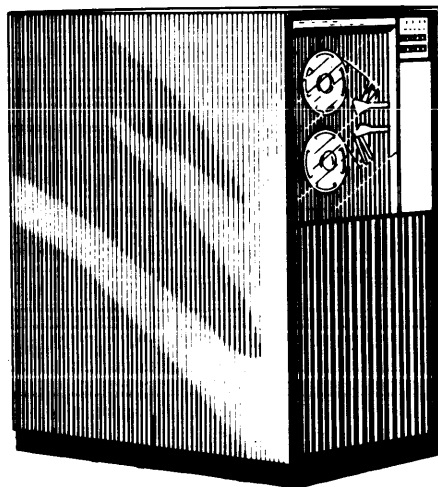

Figure 8-1. Type 4950 Magnetic Tape Unit

Table 8-1  
 TENTATIVE INSTALLATION REQUIREMENTS  
 FOR UNIVAC FILE-COMPUTER MAGNETIC TAPE UNIT.

|   |                                       |
|---|---------------------------------------|
| SIZE AND WEIGHT:<br>WIDTH (FRONT)<br>DEPTH<br>HEIGHT<br>WEIGHT                            | 30"<br>49 1/2"<br>65 1/2"<br>1200 LB. |
| CLEARANCE:<br>FRONT<br>BACK<br>RIGHT SIDE<br>LEFT SIDE                                    | 36"<br>24"<br>12"<br>12"              |
| POWER DISSIPATION:  | 2.7 KW                                |
| ELECTRIC SERVICE:<br>KVA<br>VOLTS<br>PHASE<br>MAX. LINE VARIATION                         | 3<br>208-240 VAC<br>1Ø<br>± 5%        |
| COOLING:<br>AIR CURRENT<br>HEAT DISSIPATED<br>MAX. ROOM TEMPERATURE<br>MAX. ROOM HUMIDITY | 720 CFM<br>9200 BTU/HR<br>90 F<br>90% |

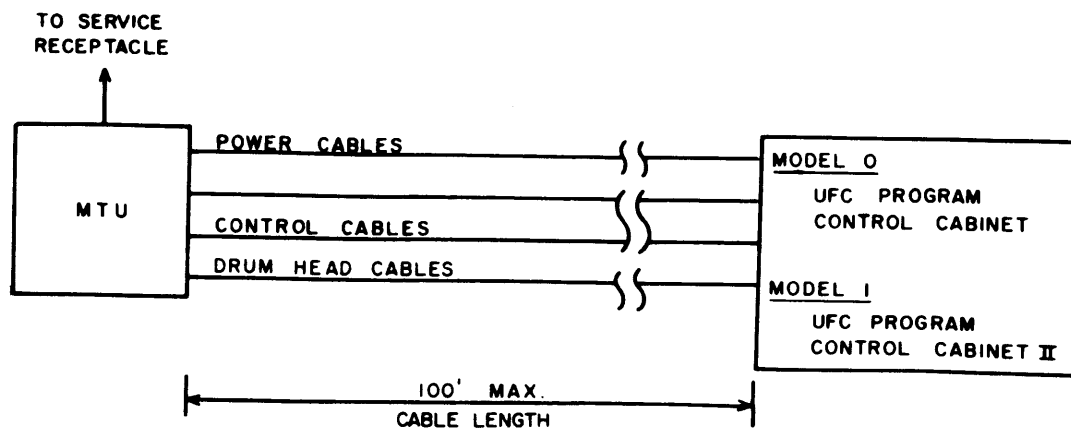

Figure 8-2. Cabling Diagram for Operation of Univac File-Computer Magnetic Tape Unit as I/O Unit

## SECTION 9

# UNIVAC FILE-COMPUTER SORT-COLLATE SYSTEM

The Univac File-Computer Sort-Collate System is a special-purpose magnetic tape file-processing device which performs a wide variety of collating operations, including a sort-by-collation and a sequence-checking operation. Although designed primarily as an independent, off-line, device for use in Univac File-Computer installations, the Univac File-Computer Sort-Collate System has a (pseudo) on-line mode of operation in Univac File-Computer systems as well. It can also be used as auxiliary, off-line, equipment for other data-processing systems. However, such systems must include at least one magnetic tape handler which is tape-compatible with the Univac File-Computer Magnetic Units described in Section 8.

### FUNCTIONAL DESCRIPTION

#### Capabilities

The function of the Univac File-Computer Sort-Collate System is the ordering of magnetic tape data (Items) according to pre-established rules.

Four Univac File-Computer Magnetic Tape Units (described in Section 8) and a Sort-Collate Unit (See Figure 9-1) compose the system. The four tape units are designed MTU I, MTU II, MTU III, and MTU IV. The specific function of each tape unit in the three general types of collation described below is given in Table 9-1. Note that, in general, each is either an input tape unit, functioning as a source to supply tape data to the system; or an output tape unit, functioning as a destination at which the system rewrites sorted or collated data. The Sort-Collate Unit controls the operation of each tape unit and executes the system programs required to order the tape data.

The ordering of tape data consists basically of these two actions:

1. A comparison of two or three units of tape data to determine the difference in magnitude between them; followed by
2. A transfer of one or more units of tape data to place them on other tape(s) in some relation to their magnitudes; i.e., in accordance with the pre-established rules.

Specifically, three major types of collation, or ordering of data, are performed; (Refer to Table 9-1)

1. Extraction: Data from a Master File is extracted or selected according to (a) one or two Key Files, and (b) a set of plugboard-defined rules called a collation program. As a result of the operation, a new file of extracted data is prepared.

If only one Key File is used, this operation can be programmed to select Items from the Master File as follows: on the basis of identity with the Items in the Key File; or on the basis of a greater than or less than relationship to an Item in the Key File.

If two Key Files are used, the operation can be programmed to select Items from the Master File between the limits specified by two other Items, one in each of the Key Files.

2. Merging: Data from two or three Master Files are combined, in accordance with plugboard-defined rules (i.e., a collation program) to form a new Master File.
3. Sorting-by-Collation: By a combination of extraction and merging, a Master File is sorted in strict relation to magnitude. The rules for this operation are defined by an ascending sort routine which is internally wired into the system. The operation is thus fully automatic.

The wired-in sort routine is also used for checking tape data for ascending sequences. In Sequence Checking operations a single pass is made through the tape data. The file checked is either sequenced in ascending order or not. A corresponding indication is given on the Sort-Collate Control Panel. If the file was in sequence, the operation automatically rewinds MTU I and MTU III tape. If the file was not in sequence, only MTU I is rewound. In any event the original Master File is rewritten (See Table 9-1). If it was not in sequence, and a sequenced version of it is required, a Sort operation can be initiated immediately after the Sequence Checking operation. (The latter operation would then be regarded by the system as the first pass of the Sort.) The subsequent Sort operation must see MTU I for intermediate storage. Hence, the original Master File on MTU I should be removed after the Sequence Checking operation, if it is necessary to keep that file in its original form.

In Extraction, Merging, and Sequence Checking operations, a single pass is made through

Table 9-1  
SORT-COLLATE TAPE UNIT ASSIGNMENTS

| TYPE OF COLLATION  | NAME OF OPERATION   | TAPE UNIT                                    | FUNCTION                        | CONTENTS   |
|--|---|--|---------------------------------|--|
| E<br>X<br>T<br>R<br>A<br>C<br>T<br>I<br>O<br>N   | EXTRACTION ON THE BASIS OF<br><br>M = K<br>M > K, OR<br>M < K     | MTU I  | INPUT                           | MASTER FILE  |
|  |   | MTU II                                       | INPUT                           | KEY FILE   |
|  |   | MTU III & IV<br>(EITHER OR BOTH CAN BE USED) | OUTPUT                          | EXTRACTED FILE   |
|  | EXTRACTION BETWEEN LIMITS:<br>K <sub>1</sub> < M < K <sub>2</sub> | MTU I  | INPUT                           | MASTER FILE  |
|  |   | MTU II                                       | INPUT                           | KEY FILE (K <sub>2</sub> )   |
|  |   | MTU III                                      | INPUT                           | KEY FILE (K <sub>1</sub> )   |
|  |   | MTU IV                                       | OUTPUT                          | EXTRACTED FILE   |
| M<br>E<br>R<br>G<br>I<br>N<br>G  | TWO-FILE MERGE  | MTU I  | INPUT                           | MASTER FILE A  |
|  |   | MTU II                                       | INPUT                           | MASTER FILE B  |
|  |   | MTU III & IV<br>(EITHER OR BOTH CAN BE USED) | OUTPUT                          | MERGED FILE  |
|  | THREE-FILE MERGE  | MTU I  | INPUT                           | MASTER FILE A  |
|  |   | MTU II                                       | INPUT                           | MASTER FILE B  |
|  |   | MTU III                                      | INPUT                           | MASTER FILE C  |
|  |   | MTU IV                                       | OUTPUT                          | MERGED FILE  |
| S<br>O<br>R<br>T<br>I<br>N<br>G<br><br>B<br>Y<br><br>C<br>O<br>L<br>L<br>A<br>T<br>I<br>O<br>N | SORT  | MTU I  | INPUT & INTERMEDIATE STORAGE    | FILE TO BE SORTED  |
|  |   | MTU II                                       | INTERMEDIATE STORAGE            |  |
|  |   | MTU III                                      | INTERMEDIATE STORAGE AND OUTPUT | SORTED FILE  |
|  |   | MTU IV                                       | INTERMEDIATE STORAGE            |  |
|  | SEQUENCE CHECKING   | MTU I  | INPUT                           | FILE TO BE CHECKED   |
|  |   | MTU II                                       | NOT USED                        |  |
|  |   | MTU III                                      | OUTPUT                          | IF FILE TO BE CHECKED IS ALREADY IN ASCENDING SEQUENCE, THE FILE IS DUPLICATED ON MTU III; IF THE FILE TO BE CHECKED IS NOT IN ASCENDING SEQUENCE, ALL OF ITS ITEMS ARE REWRITTEN, BUT SOME ARE ON MTU III, AND THE OTHERS ARE ON MTU IV |
|  |   | MTU IV                                       | OUTPUT                          |  |

the tape data. The time required for these operations is given by:

$$T = 28.5 N \text{ (for tapes with 0.5'' blockette spacing)}$$

$$\text{or } T = 34.5 N \text{ (for tapes with 1.0'' blockette spacing)}$$

where  $T$  = the time required, in milliseconds; and

$N$  = the number of blockettes to be read in the operation.

Sort operations require a number of passes through the tape data. The time required for sorting depends on (a) the number of Items to be sorted, (b) the length of the Items to be sorted, and (c) the number of natural sequences already in the Items. Usually, (a) and (b) can be accurately determined rather easily. On the other hand (c) is sometimes impossible to determine. In this connection, the following equation may be used:  $\bar{E}(S) = \frac{n}{2,4}$ , where  $\bar{E}(S)$  is the expectation of the number of natural sequence in the file to be sorted, and  $n$  is the number of random Items in the file. The following equations are to compute (or, if  $\bar{E}(S)$  is used for  $S$ , to estimate) Sort times:

$$T = 28.5 N \left\{ \left[ \log_2 S \right] + 1 + \left[ \log_2 S \right] \pmod{2} \right\} \text{ (for tapes with 0.5'' blockette spacing)}$$

$$T = 34.5 N \left\{ \left[ \log_2 S \right] + 1 + \left[ \log_2 S \right] \pmod{2} \right\} \text{ (for tapes with 1.0'' blockette spacing)}$$

where  $[ ]$  = the next greater integer

$N$  = the number of blockettes in the file

$S$  = the number of natural sequences

In all three types of collation, the Item is the system's unit of tape data. Items are compared and Items are transferred, even though each of the tape units operates on a blockette basis. When Items are originally recorded on tape, their length is defined by the recording program. Normally, all Items in a given file are of the same length. It is sometimes necessary or convenient, however, to vary the length of Items within a file; and it is quite common that Items in separate files have different lengths. Accordingly, the following rules relative to Item length have been established for the Sort-Collate System:

1. Item lengths of 60 characters or  $120n$  characters, where  $n = 1, 2, 3, \dots, 10$ , are permitted.
2. All Items in files to be sorted or checked for ascending sequences must be of the same length. Items in files processed by plugboard-defined collating programs need not all be of the same length, but it is more convenient (programwise) if they are.

3. In all operations of the Sort-Collate System, the Item length (or lengths) involved in the operation must be defined by patchcord wiring on the Sort-Collate Plugboard. Each time the Sort-Collate System begins a new step in its program it refers to the Item length defined on the plugboard. If the Item length specified at that time, for example, is 480 characters, and the step calls for a transfer to occur, the system will automatically transfer 480 characters, 120 at a time.

Another factor which must be defined for the System by patchcord wiring on the Sort-Collate Plugboard, regardless of the type of collation being performed, is the basis on which the system is to compare Items. By definition an Item is a complete, unique file entry. Each Item, therefore, not only completely defines a given file entry, but also contains a prime set of identifying data which distinguishes it from all other Items in a file.

For Items of 120 characters or more, this prime set of identifying data can vary from 1 up to 120 characters in length; for 60-character Items, it can vary from 1 up to 60 characters in length. In 60 and 120-character Items the prime set of identifying data is contained in the first and last blockettes of the Item. When Items are compared, only each's prime set of identifying data is used. In some cases, the entire prime set of identifying data is employed; in other cases only a portion. To make it possible to do Item comparison on the basis of any set of data included in the prime set of identifying data, the specific character positions that are to be used in the comparison of Items are plugboard-defined. These character positions are called Compare Positions.

For Items of 120 characters or more, Compare Positions are defined on a Word (0-9) and Character (11 through S) basis. Word 0, Character 11 is the most significant Compare Position. This corresponds to the character written first on the tape when the Item was recorded. Word 0, Character 10 is the next most significant Compare Position, etc. Word 9, Character S (Sign) is the least significant Compare Position. This corresponds to the last character written on the tape when the Item (or, in the case of multiblockette items, the first blockette of the Item) was recorded.

In the case of 60-character Items, exactly two Items are stored in each blockette on the tape. Accordingly, the 120 Compare Positions are divided into two parts: Word 0, Character 11 through Word 4, Character S are used for the first Item; and Word 5, Character 11 through Word 9, Character S are used for the second Item. Word 0, Character 11 is the most significant Compare Position for the first Item in the blockette; and Word 4, Character S is the least significant Compare Position for the first Item in the blockette. Word 5, Character 11 is the most significant Compare Position for the second Item in the blockette; and Word 9, Character S is the least significant Compare Position for the second Item in



the blockette. When 60-character Items are used in any Sort-Collate operation, (a) all Items in each file involved must be 60-character Items, and (b) both halves of the Compare Position hubs must be identically wired.

Regardless of the Item length employed, the Compare Positions plugged need not represent contiguous character positions in the prime set of identifying data. That is, the prime set of identifying data can be partitioned. In the case of Items of 120 characters or more, 4 groups of Compare Positions can be specified. In the case of 60-character Items (where two identical sets of Compare Positions must be plugged) only 2 groups of Compare Positions can be specified. Compare Positions within any group, however, represent contiguous character positions.

Since Sort and Sequence-Checking operations are fixed-program operations defined by internal wiring, the only plugboard patching that must be done for those operations is that outlined above for specifying the Item Length and Compare Positions.

In Extraction and Merging operations however, the Entire Collation Program (i.e., the set of complete rules for the collation) is also defined by patchcord wiring. This involves appropriate patching of a combination of up to 12 Collation Steps and a variety of other hubs on the Sort-Collate Plugboard.

Each Collation Step is an instruction (or principal step) in a plugboard-defined collation program. The required combination of the following hubs is patched to define a Collation Step:

- STEP IN        - to initiate the Collation Step.
  
- PROCESS        - to define the basic operation to be performed during the Collation Step. Any one of four processes can be specified, depending on the function desired of this Collation Step in the program:

- Transfer
- Compare
- Load Data
- Write End of Data

(These processes are described in detail under Basic Processes below.)

- SOURCE** - to specify which of the permissible input tape units (MTU I, MTU II, or MTU III) is to supply data for this Collation Step (See Table 9-1).
- DESTINATION** - to specify which of the permissible output tape units (MTU III or MTU IV) is to receive data as a result of this Collation Step (See Table 9-1).
- STEP OUT** - to control the sequencing of the collation program.

Transfer processes, in general, require specification of both source and destination. In Load processes, only the source is specified. In Write End of Data processes, only the destination is specified. No source or destination is involved in a Compare Process. However, the results of each Compare process are sent to other hubs on the plugboard. These hubs must be wired to define the basic rules of the collation.

The Sort-Collate System can be incorporated into Univac File-Computer installations in either of two configurations:

1. It can be included as a device which shares control of the four tape units with the computer. In this configuration (See Figure 9-2) cabling from the Sort-Collate Unit is connected to the computer, part of the cabling from the four tape Unit Demand Stations is connected to the Sort-Collate Unit; and the other part of the cabling from each of the four tape unit Demand Stations is connected to the computer. Three types of activity can be carried out, depending on the setting of an OPERATION MODE switch on the Sort-Collate Control Panel:
  - a) When this switch is set to its DEMAND position, each tape unit is directly and exclusively controlled by the computer. In short, the operation of the tape units the same as if each were directly plugged into the computer as I/O Units (See SECTION 8).
  - b) When this switch is set to its SORT position, each tape unit is directly and exclusively controlled by the Sort-Collate System's internally-wired sort routine. No communication with the computer is possible, since Sort-Collate Control places each tape unit in a NOT READY status.
  - c) When this switch is set to its PROGRAM COLLATE position, each tape unit is, in general, controlled by a plugboard-defined collation program.

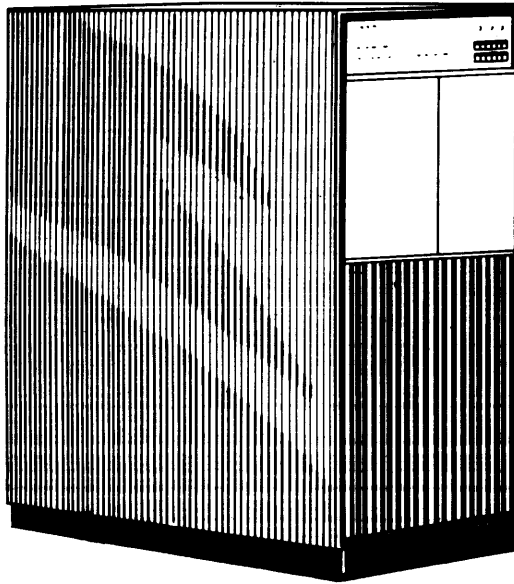
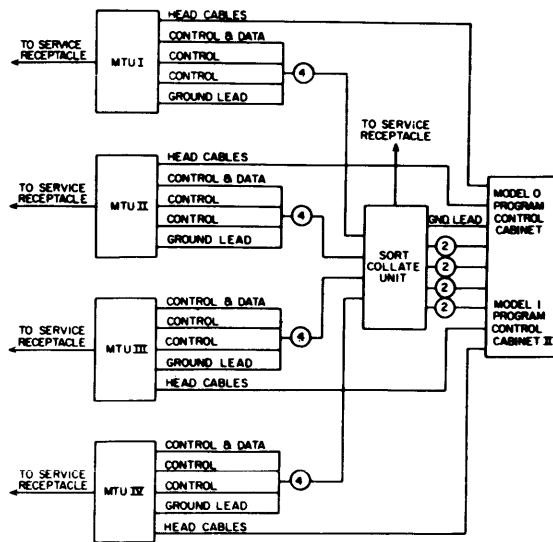

Figure 9-1. Sort-Collate Unit



(ALL CABLE LENGTHS MUST BE LESS THAN 100')

Figure 9-2. Cabling Diagram for (psuedo) On-Line Operation of Univac File-Computer Sort-Collate System

While the tape units are performing the plugboard-defined collation operations, Sort-Collate Control maintains each in a NOT READY status. However, as explained later in this section under Computer Alert, if the collation program is so patched, the collating operations of the tape units can be interrupted; each tape unit can be placed in a READY condition; and control of the tape units turned over to the computer. Each tape unit can thereafter function as an I/O Unit for the computer. The purpose of the Computer Alert feature is to permit collating and file updating operations to be performed in a single pass through the tape data. Upon completion of its updating routine, the computer returns control of the tape units to the Sort-Collate System. If the patchcord wiring defining the collation program so specifies, the collating operation continues automatically thereafter. Subsequent Computer Alert operations can be carried out if the collation program is so patched.

Regardless of its activity, when the Sort-Collate System is connected in Univac File-Computer installations in the above configuration, four Demand Station positions are used by the tape units. (The Sort-Collate Unit does not have a Demand Station position, as such; however, it has certain circuitry very similar to that in a Demand Station. In Computer Alert operations, MTU I's Demand Station is "borrowed" by the system to notify the computer that Computer Alert has been initiated. Sort-Collate's pseudo Demand Station then communicates with the computer to achieve the tape unit control exchanges).

2. It can be included as an independent device which operates completely apart from the computer. In this configuration (See Figure 9-3) the four tape units are plugged into the Sort-Collate Unit; no connections are made to the computer. No Demand Stations are used; hence, no operations can be performed if the OPERATION MODE switch is set to its DEMAND position. When the OPERATION MODE switch is set to its SORT position, only sort and sequence checking operations can be performed. In this case the four Univac File-Computer Magnetic Tape Units are directly and exclusively controlled by the internally wired sort routine. When the OPERATION MODE switch is set to its PROGRAM COLLATE position, the four tape units are exclusively controlled by a (plugboard-defined) collation program.

From 2. above it follows that the Sort-Collate System can be used off-line in conjunction with any data-processing system whose magnetic tape is compatible with that used in the Univac File-Computer Magnetic Tape Units.

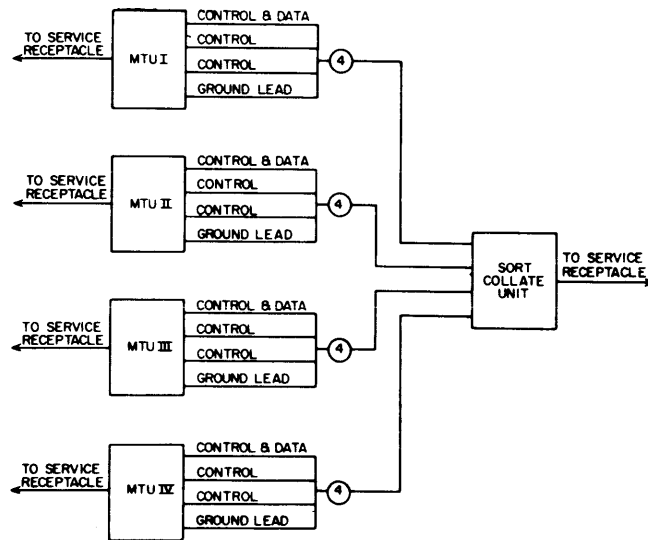

(ALL CABLE LENGTHS MUST BE LESS THAN 100')

Figure 9-3. Cabling Diagram for Independent Operation of Sort-Collate System

#### Medium:

Mylar magnetic tape, as described in Section 8, is the medium employed. In addition to those specifications listed in Section 8, the following are requirements for tapes to be used in the Sort-Collate System:

1. All Items in each file involved in any Sort-Collate program must have their prime set of identifying data arranged in the same pattern.
2. In multiblockette Items, this prime set of identifying data must be in the first and last blockettes of each Item.
3. End of File and End of Data codes (normally 12 "Z's" and 12 "%s" respectively) must each be recorded as full Items.
4. An End of Data Item must be recorded as the last Item on every input tape.
5. If the first item on a tape is the tape reel's label, the data used for labelling must be located in character positions other than those used for the prime set of identifying data for the Items in the file. In general, in Label Items all character positions other than the actual label characters should be ignore codes.

6. Files to be sorted or to be checked for ascending sequence must consist exclusively of Items of the same length; this is not a requirement for other collating operations involving Items of 120 characters or more, since selectors can be operated via patchcord wiring on the Sort-Collate Plugboard to vary the system's Item Length as required. Files containing Items of 60 characters in length cannot be collated with files containing any other Item lengths.

## Basic Processes

Every program carried out by the Sort-Collate System consists of a series of steps or instructions. Each step involves one of the following basic processes:

Transfer  
Compare  
Load  
Write End of Data

Transfer. The Transfer process is used to transmit an Item from one tape unit (designated as the source) to one or two other tape units (designated as the destinations). This process assumes:

- a) that the Item (or, in the case of multiblockette Items, that the first blockette of the Item), has already been loaded into the buffer of the tape unit designated as the source;
- b) that the SOURCE and DESTINATION hubs on the plugboard are appropriately patched; and
- c) that an Item length is specified by patchcord wiring on the plugboard.

Although the Transfer process is basically the same regardless of the Item length involved, it is convenient to discuss separately the transfer cycles for 120 character Items, multiblockette Items, and 60 character Items. (One destination only is discussed).

If the plugboard-defined Item length is 120 characters, or one blockette:

The Item in the source tape unit's buffer is transferred to the destination tape unit's buffer; then

The source tape unit reads the next Item from its tape into its buffer; and the con-

tents of the destination tape unit's buffer are recorded on that tape unit's tape.

The process terminates with the Item transferred being written on an output tape (but still "remembered" in the destination tape unit's buffer); and a new Item loaded into the source tape unit's buffer. Note that, basically, a Transfer process is a blockette operation to the tape units.

If the plugboard-defined Item length is a multiblockette length, the above one-blockette sequence is repeated as many times as there are blockettes in the Item. In this case, when the operation terminates:

the entire multiblockette Item to be transferred has been recorded on the destination tape;

the blockette containing the prime set of identifying data for the Item transmitted is "remembered" in the destination tape unit's buffer (this data was the last blockette recorded); and

the blockette containing the prime set of identifying data for the next Item on the source tape unit's tape is in that tape unit's buffer.

If the plugboard-defined Item length is 60 characters or 1/2 blockette, the buffer-to-buffer transmission in transfer cycles are 60-character transmissions. The Sort-Collate System automatically cycles through the source tape unit's buffer and the destination tape unit's buffer and the destination tape unit's buffer. In short, it "remembers" where to get the next Item (i.e., in which half of the source tape unit buffer); and it also "remembers" where to put each output Item (i.e., in which half of the destination tape unit's buffer it is to load the Item). The source tape unit, however, will read a new blockette from its tape only if both sections of its buffer have been exhausted by transfers. Similarly, the contents of a destination tape unit's buffer are written only if both sections are filled.

Compare. The Compare process is used to determine the relative magnitudes of three items: I (the Item in MTU I), II (the Item in MTU II) and L (the Item last transferred). The process assumes

a) that MTU I and MTU II's buffers already contain the prime set of identifying data for items I and II, respectively. (The prime set of identifying data for the last Item transferred, L, is automatically "remembered" in the tape unit that received L. See Transfer above:

b) that the Compare Positions, that is the character positions in the prime sets of

identifying data which are actually to be compared, are defined by patchcord wiring on the Sort-Collate Plugboard; and

c) that the result hubs of the Compare process are appropriately patched.

Comparison is accomplished on a character by character basis; comparison being suppressed in those character positions not defined by Compare Position patching the plugboard. (Note; "ignore" codes do not suppress comparison in the positions in which they occur.) Three of nine possible results ( $I > II$ ,  $I = II$ ,  $I < II$ ;  $I > L$ ,  $I = L$ ,  $I < L$ ;  $II > L$ ,  $II = L$ ,  $II < L$ ) are obtained. These results are presented wither to the internally-wired sort routine, or to hubs on the Sort-Collate Plugboard. At the conclusion of this process, the tape unit buffers involved remain unchanged. No transfer of data occurs; hence, no source or destination designations are made.

Selectors:

The four types of selectors provided in the Sort-Collate System, and the number and function of each type are given in Table 9-2.

Load. The Load process is used to transfer a blockette of information from the tape in one, two, or three tape units (designated as sources) to those tape units' buffers. The Load process is a "starting" process, primarily.

Write End of Data. This process can be used to write an Item of End of Data codes on one or two output tapes. The system automatically produces an Item length of End of Data codes; therefore, no source need be specified. However, the tape units on whose tape an End of Data Item is to be recorded must be designated as destinations. In the case of 60 character Items, two Write End of Data processes must be programmed to insure that the Item of End of Data is actually written on the output tape. (See 60-character case, in Transfer above).

Terminal Conditions:

The following terminal conditions, when detected in input tape units MTU I, MTU II, or MTU III, are used for program variance in Sort-Collate programs;

End of File  
End of Data

Only one terminal condition from the output tape units MTU III and MTU IV is used for program variance:



Table 9-2

SORT-COLLATE SELECTORS

| TYPE               | NUMBER | OPERATED BY   | FUNCTION(S)   |
|--------------------|--------|---|---|
| PROGRAM SELECTORS  | 4      | ANY PULSE ON SORT-COLLATE PLUGBOARD, EXCEPT THOSE DUE TO TERMINAL CONDITIONS (DISCUSSED BELOW), CAN BE ROUTED BY PATCHCORD WIRING TO "PICK-UP" OR "DROP-OUT" PROGRAM SELECTORS. | (A) TO OPERATE RELAY SELECTORS: DC POWER IS SUPPLIED FROM THE TIME A PROGRAM SELECTOR IS "PICKED UP" UNTIL IT IS "DROPPED OUT".<br><br>(B) TO DELAY "PICK-UP" PULSE. THE PICK-UP PULSE IS DELAYED 10MS. TO MAKE CERTAIN THE RELAY SELECTOR INVOLVED IS ACTIVATED BEFORE IT IS PROBED. (THIS DELAY OCCURS, HOWEVER, WHETHER OR NOT PATCHCORD WIRING IS PROVIDED TO "PICK-UP" A RELAY SELECTOR) |
| TERMINAL SELECTORS | 4      | ONLY PULSES DUE TO THE OCCURRENCE OF TERMINAL CONDITIONS SHOULD BE PATCHED TO "PICK-UP" TERMINAL SELECTORS. ANY PULSE CAN BE ROUTED TO "DROP-OUT" THESE SELECTORS.              | (A) TO OPERATE RELAY SELECTORS. (SAME AS FOR PROGRAM SELECTORS)<br><br>(B) TO DELAY A STEP OUT PULSE. THE NEXT STEP OUT AFTER THE OCCURRENCE OF THE TERMINAL CONDITION IS DELAYED 10MS. TO MAKE CERTAIN ANY RELAY SELECTOR INVOLVED IS ACTIVATED BEFORE IT IS PROBED.   |
| RELAY SELECTORS    | 12     | PROGRAM OR TERMINAL SELECTOR POWER  | TO ALTER THE PATH OF PLUGBOARD SIGNALS FOR PROGRAM VARIANCE.  |
| PROGRAM ALTERATION | 4      | MANUAL SETTING OF TOGGLE SWITCHES ON THE SORT-COLLATE CONTROL PANEL.  | SAME AS RELAY SELECTORS.  |

## End of Blockette Count

In Sort-and Sequence-Checking operations these conditions are presented to the internally-wire routine and are automatically interpreted therein. In all other operations they are presented to the plugboard-defined program as signals on the Sort-Collate Plugboard. The hubs which receive them must be appropriately patched to other hubs to effect program variance. So as not to conflict with or interrupt plugboard-defined collation programs, it is necessary

- (a) that the terminal condition hubs on the Sort-Collate Plugboard be wired only to Terminal Selector pick-ups; and
- (b) that the POWER OUT hubs from each Terminal Selector be wired to those Relay Selectors used for program variance.
- (c) that plugboard-defined collation programs be designed to probe the program variance selectors, as required, to decide whether to terminate the collating operation, to rewind the tape on a particular tape unit, branch into a new set of Collation Steps, etc.

### Rewind Operations:

The system is made aware of the necessity to rewind by the occurrence of one of the terminal conditions listed above.

After Extraction and Merging operations (or, during these operations if more than 1 reel of tape is required) Rewind operations must be provided for by patchcord wiring on the Sort-Collate Plugboard. The appropriate REWIND (IN) hub, I, II, III, or IV must be pulsed to initiate a Rewind operation in an MTU.

In Sequence Checking operations, the system automatically rewinds the tape in MTU I and MTU III (See Figure 9-1), if the file to be checked proved to be in ascending sequence. If the file checked was not in ascending sequence, only MTU I is automatically rewound.

All tape units are automatically left in a rewound condition after Sort operations.

Every Rewind operation in the Sort-Collate System automatically interlocks the tape unit(s) involved. Once an interlock is set up, it continues until it is manually removed, either by operating controls on the interlocked tape unit or by pressing the MASTER CLEAR button on the Sort-Collate Control Panel.

When a tape unit is in its rewind-with-interlock condition, the source tape reel can be changed, but the tape unit cannot be used. Accordingly, in plugboard-defined collation programs, the program should not be designed to attempt other operations once it initiates a Rewind.

To resume operation after a plugboard-defined collating program has been interrupted for Rewind.

- (1) any reel changing required is performed;
- (2) manual controls on the tape unit(s) rewind are operated to remove the interlock(s);
- (3) the START button on the Sort-Collate Control Panel is pressed. (The START button is not effective unless all interlocks are removed.)

The program will then be re-initiated from the point specified by patchcord wiring from the REWIND OUT hub on the Sort-Collate Plugboard.

Pressing the MASTER CLEAR button on the Sort-Collate Control Panel automatically removes all tape unit interlocks. ( If the MASTER CLEAR button is pressed after a Rewind which interrupts a collation program, and the START button is subsequently pressed, the collation program is re-initiated from the START hub on the Sort-Collate Plugboard.)

#### Computer Alert Operations;

To permit more efficient use of the tape units and to provide a faster method of updating tape files, a Computer Alert operation has been made available in the Sort-Collate System.

Computer Alert can be performed when the following conditions are met:

1. The Sort-Collate System is connected to a Univac File-Computer in the configuration shown in Figure 9-2;
2. The OPERATION MODE switch on the Sort-Collate Control Panel is set to its PROGRAM COLLATE position;
3. Patchcord wiring on the Sort-Collate Plugboard specific Computer Alert as part of the plugboard-defined collation program. This means that at some point (or at certain points, if a series of Computer Alert operations are to be performed) patchcord wiring must cause one of the 15 COMPUTER ALERT hubs on the Sort-

Collate Plugboard to be pulsed. In Model 1 systems this is sufficient to initiate the Computer Alert operation, and define a particular one of 15 updating routines for the computer. In Model 0 systems a COMPUTER ALERT hub must also be pulsed; but, if a particular updating routine is to be specified for the computer, a network of Sort-Collate Selectors must be activated during or prior to each Computer Alert Operation.

Even though Computer Alert operations are anticipated, the computer can be involved in a totally unrelated program, as long as it tests the status of MTU I periodically. When the Sort-Collate System has control of the tape units, each Demand Test In by the computer of MTU I will result in a NOT READY signal from Sort-Collate Control.

When a COMPUTER ALERT hub on the Sort-Collate Plugboard is pulsed:

1. Collating stops
2. A copy of the 120 characters held in each tape unit's buffer is written on the I/O Track associated with that tape unit.
3. Control of the four tape units is then turned over to the computer, i.e., each tape unit goes READY, all of its Demand Station control lines are released by Sort-Collate Control, and data transmissions to and from each tape unit's associated I/O Track can take place under computer control.

After a Demand Test in sequence wherein the Computer detects that Computer Alert has been initiated (i.e., when the computer finds MTU I READY) it must then carry out a Demand In sequence specifying MTU I. This Demand In sequence actually occurs in the Sort-Collate Unit, not (as programmed) in MTU I. As a result of this Demand in sequence the following occur:

In Model 1 Systems, a SPECIAL OUT is generated and a binary-coded number, corresponding to the COMPUTER ALERT hub pulsed, is sent to the computer's High-Speed IO-to-Computer Control Line Storage; the computer must then test High-Speed IO-to-Computer Control Line Storage and determine its updating routine. (Thereafter, any Demand In sequences involving MTU I actually occur in MTU I.)

In Model 0 Systems, a DEMAND OUT is generated by Sort-Collate Control; and, the updating routine for the computer, if a particular one is to be specified, is given by a combination of d-c enables over the relay operated IO-to-Computer control lines, h-k. (These d-c enables are produced by Sort-Collate Selectors which must be activated via appropriate patchcord wiring on the Sort-Collate Plugboard.)

When the computer has completed the specified updating routine, it can be programmed to (a) demand any MTU to give it a TRANSFER IO TRACK-TO-BUFFER instruction; and simultaneously pulse one of the Computer-to-IO control lines E through I to revert subsequent control of all tape units to Sort-Collate Control; or (b) it can pulse the Computer-to-IO control lines E through I without demanding any MTU. In either case this will initiate the transfer of tape unit control from the computer to the Sort-Collate System. In (a) it will also send updated data to one MTU. If other MTU's are to receive updated data, each must be separately demanded and given a TRANSFER TO TRACK-TO-BUFFER instruction.

When Sort-Collate Control receives a signal over any one of the Computer-to-IO control lines E through I, it routes this signal to the correspondingly labelled hub E through I on the Sort-Collate Plugboard. If collating operations are to continue after Computer Alert the E through I hub pulsed must be patched to the RESUME IN hub on the plugboard. When a RESUME IN signal is generated, Sort-Collate Control knows collating is to continue. It then tests to see if a TRANSFER IO TRACK-TO-BUFFER instruction (or any other instruction) was given one or more MTU's. Sort-Collate Control does not attempt to resume collating operations until all operations specified by the computer are completed.

When the tape units have finished with the computer-defined operations, Sort-Collate Control assumes complete control of each tape unit, and issues a RESUME OUT pulse at the correspondingly labelled hub on the plugboard. Collation continues from the point to which this hub is patched.

Checking:

In addition to the parity and 120 count checks made during data transmissions to and from each tape unit's buffer, every character compared is parity checked, and checking is done during Rewind operations.

#### PHYSICAL DESCRIPTION

The Sort-Collate System is composed of five cabinets: four Univac File-Computer Magnetic Tape Units (See Figure 8-1) and a Sort-Collate Unit (See Figure 9-1).

The tentative installation requirements for each of the Univac File-Computer Magnetic Tape Units are given in Section 8, Page 8-8. Those for the Sort-Collate Unit are listed in Table 9-3.

Figure 9-2 is a cabling diagram for the connections made in the (psuedo) on-line operation of the Sort-Collate System. Figure 9-3 is a cabling diagram for the connections made in the completely independent operations of the Sort-Collate System.

Table 9-3

TENTATIVE INSTALLATION REQUIREMENTS  
FOR THE SORT-COLLATE UNIT

*(Sort-Collate System requirements include those listed below plus those given on Page for each of the Univac File-Computer Magnetic Tape Units)*

|  |  |
|--|--|
| <b>SIZE AND WEIGHT:</b><br>WIDTH<br>DEPTH<br>HEIGHT<br>WEIGHT                                    | 30"<br>49 1/2"<br>65 1/2"<br>1200 LB       |
| <b>CLEARANCE:</b><br>FRONT<br>BACK<br>RIGHT SIDE<br>LEFT SIDE                                    | 36"<br>24"<br>12"<br>12"                   |
| <b>POWER DISSIPATION:</b>  | 5.9 KW                                     |
| <b>ELECTRIC SERVICE:</b><br>KVA<br>VOLTS<br>PHASE<br>MAX. LINE VARIATION                         | 6.6<br>220 VAC<br>10<br>± 5%               |
| <b>COOLING:</b><br>AIR CURRENT<br>HEAT DISSIPATED<br>MAX. ROOM TEMPERATURE<br>MAX. ROOM HUMIDITY | 1000 CFM<br>20,136 BTU/HR.<br>90 F<br>80 % |

## SECTION 10

# UNIVAC FILE-COMPUTER HIGH-SPEED PRINTER

The Univac File-Computer High-Speed Printer operates as on-line or off-line output equipment for the Univac File-Computer System. It is capable of printing alpha-numeric data in 130 columns at a maximum rate of 600 lines per minute. Automatic checking circuitry insures against faulty printer operation. In one-line operation, the printer operates as an output unit of the computer, obtaining information and control signals from the computer. In off-line operation, the printer operates with a Univac File-Computer Magnetic Tape Unit as its source of input information. The basic equipment features and mechanical specifications are essentially the same as those of the off-line printer currently used in the Univac I system. Internal logic and circuit techniques have been revised, however, to effect cost and power reductions and to permit on-line operation in the Univac File-Computer System.

### FUNCTIONAL DESCRIPTION

#### Specifications

|   |   |
|---|---|
| CHARACTERS PER LINE:                      | 130 MAXIMUM   |
| LINES PER MINUTE:                         | 400 OR 600  |
| HORIZONTAL CHARACTER SPACING:             | 10 PER INCH (PICA TYPE)   |
| VERTICAL LINE SPACING:                    | 6 LINES PER INCH (SINGLE, DOUBLE, OR TRIPLE SPACED)                                   |
| NUMBER OF DIFFERENT PRINTABLE CHARACTERS: | 51 (10 NUMERIC, 26 ALPHABETIC, 15 PUNCTUATION AND SPECIAL SYMBOLS)                    |
| PAPER STOCK:                              | ANY STANDARD SPROCKET-FED PAPER (4 TO 27 INCHES IN WIDTH, UP TO CARD STOCK IN WEIGHT) |
| NUMBER OF CARBON COPIES:                  | DEPENDS ON WEIGHT OF PAPER (AT LEAST 4 USING 12 POUND STOCK)                          |

#### Information Coding

The information fed into the printer must be expressed in blockettes of Univac characters. One blockette contains 120 seven-bit Univac characters; these characters are used in printing one line in single line operation, and up to six lines in multiline operation. Each blockette is loaded into the printer in a serial-bit, serial-character manner.

## Format Control

The output format of the printer is controlled by plugboard patching, by special control characters in the blockettes, by the fast feed control loop, and by control signals both from the computer and from the printer itself. The following variations in format can be obtained.

Selection of Print Columns. The plugboard can be patched to permit printing of any character of a blockette in any one, two, or three print columns.

Fast Feed. Paper may be spaced past large gaps in the printed format to save operational time. Five different fast feeds may be programmed; the stopping point of each is determined by the location of a hole punched in a designed channel on the fast feed control loop. In one-line operation, four of the fast feeds are started by appropriate control-line instructions from the computer, the fifth is started by a hole in the designated channel of the fast feed control loop. In off-line operation, four of the fast feeds are started by designated fast feed special characters in the blockettes; the fifth is started by a hole in the designated channel of the paper feed control loop.

Multiline. A multiline special character causes the information in the blockette to be printed out in a predetermined format on up to six successive print lines. Within limits, any blockette character can be printed on any combination of six lines and in any one, two, or three print columns of any line. The number of lines to be printed and the format of each line are determined by plugboard patching.

Zero Suppression. None-significant zeros may be suppressed and replaced with spaces in pre-selected fields of the printed output. The plugboard determines the location and size of each zero-suppression field. Different fields may be selected for single line and multiline operation. Up to 18 fields each may be selected for single line and multiline operation.

Suppression of Print-Out by Class. In off-line operation, five special characters are available as identifiers for specific classes of information. When stored in a blockette, one of the special characters signifies that the information in that blockette belongs to the class represented by that character. Each "class" character is separately identified by the printer and may be selected for suppression of print-out of each blockette containing the character.



Form Sensing. The paper feed control loop, in addition to its use in fast feed operation, may be used to inform the computer when certain locations have been reached on the paper form. Holes punched in appropriate columns of the control loop generate signals which may be used to modify the computer program.

### Control Signals

Off-Line. During off-line operation, printer operation may be modified by any of the following special control characters stored in the blockettes:

- (1) Fast Feed 1, Fast Feed 2, Fast Feed 3, Fast Feed 4
- (2) Multiline
- (3) Breakpoint
- (4) Stop

On-Line. During on-line operation, the printer is controlled from the computer, and any special control characters contained in the blockettes are ignored. The following control signals transmitted over Computer-to-IO control lines affect printer operation:

- (1) Print
- (2) Fast Feed 1, Fast Feed 2, Fast Feed 3, Fast Feed 4
- (3) Multiline
- (4) Double Space
- (5) Triple Space

The form sensing signals from the paper feed control loop are sent over IO-to-Computer control lines, and may be used to modify the computer program.

## PHYSICAL DESCRIPTION

### General

The High-Speed Printer consists of two units, the type 4990 printer unit and the type 4890 printer control cabinet (See Figures 10-1 and 10-2). The printer unit contains the print head and related mechanisms and circuitry. The printer control cabinet contains the printer control circuitry and demand station control circuitry. In off-line operation, a Univac File-Computer Magnetic Tape Unit is required in addition to the printer and control units. Table 10-1 lists the tentative installation requirements. Figures 10-3 and 10-4 are the cabling diagrams.

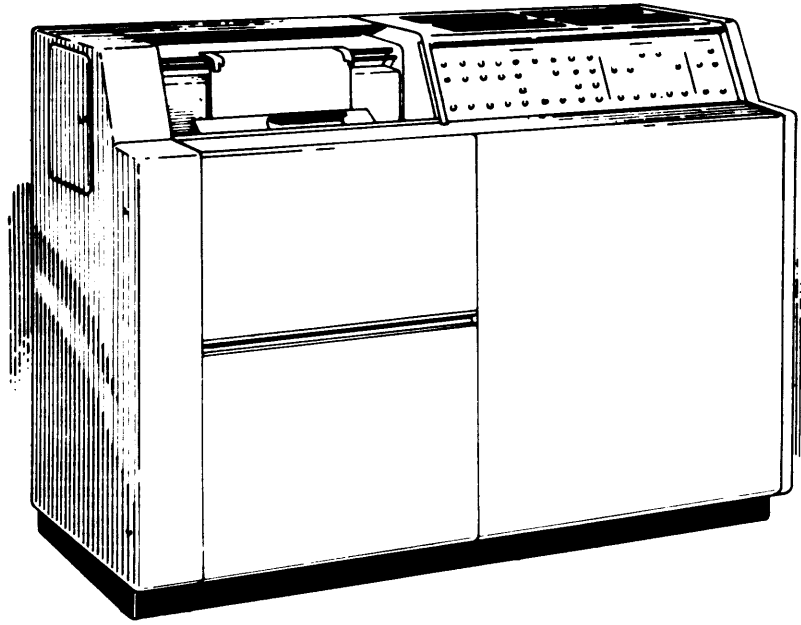

Figure 10-1. Type 4990 Printer Unit

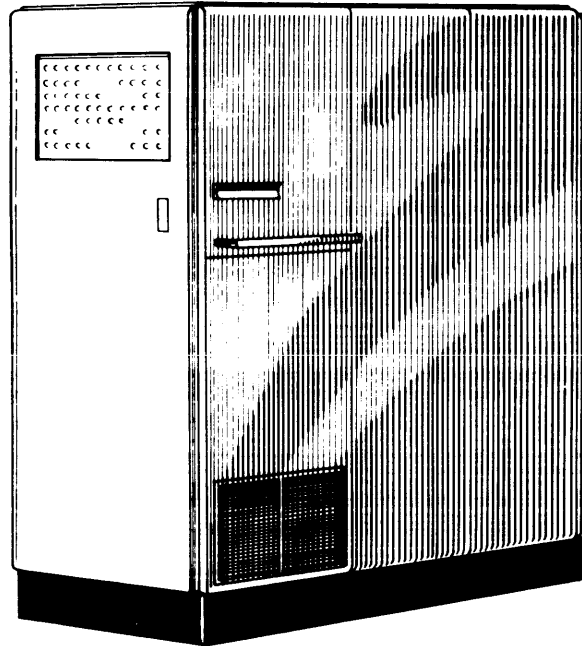

Figure 10-2. Type 4890 Printer Control Cabinet

Table 10-1  
**TENTATIVE INSTALLATION REQUIREMENTS  
 OF HIGH-SPEED PRINTER**

|  | PRINTER UNIT                                       | PRINTER CONTROL CABINET           |
|--|--|-----------------------------------|
| <b>SIZE AND WEIGHT:</b><br>WIDTH<br>DEPTH<br>HEIGHT<br>WEIGHT                                    | 72"<br>31"<br>52"<br>1500 LB.                      | 30"<br>80"<br>70 3/16"<br>2200 LB |
| <b>CLEARANCE:</b><br>FRONT<br>BACK<br>RIGHT SIDE<br>LEFT SIDE                                    | 36"<br>36"<br>36"<br>36"                           | 36"<br>30"<br>36"<br>36"          |
| <b>POWER DISSIPATION:</b>  | 7 KW   |                                   |
| <b>ELECTRIC SERVICE:</b><br>KVA<br>VOLTS<br>PHASE<br>MAX. LINE VARIATION                         | 9<br>208-240 VAC<br>3Ø-4 WIRE OR 1Ø-3 WIRE<br>± 5% |                                   |
| <b>COOLING:</b><br>AIR CURRENT<br>HEAT DISSIPATED<br>MAX. ROOM TEMPERATURE<br>MAX. ROOM HUMIDITY | 2500 CFM<br>23,000 BTU/HR.<br>90 F<br>90 %         |                                   |

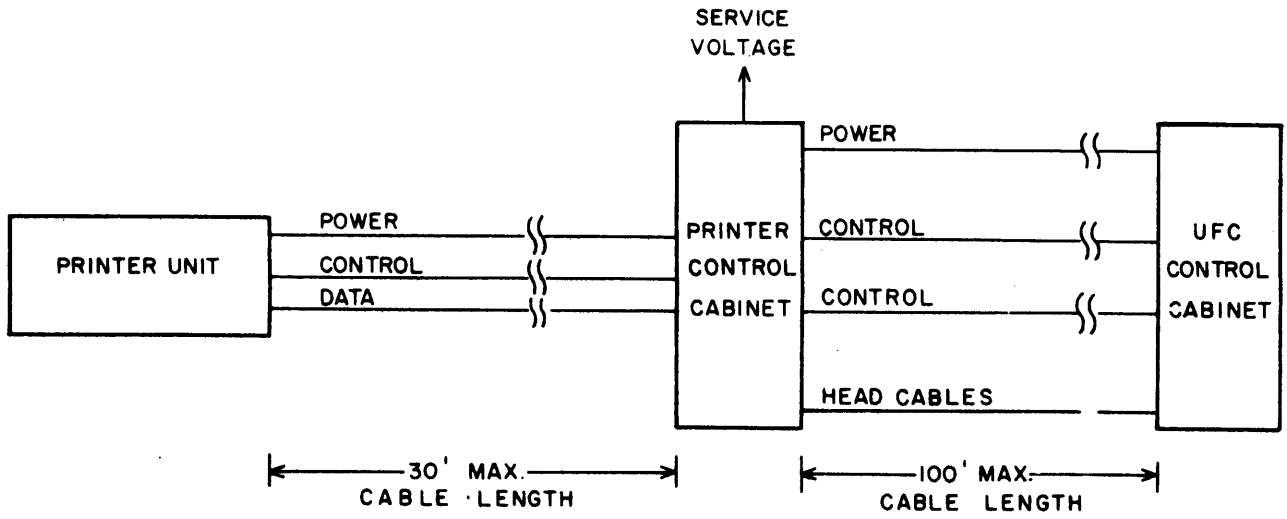

Figure 10-3. Cabling Diagram for Univac File-Computer High-Speed Printer (On-Line Operation)

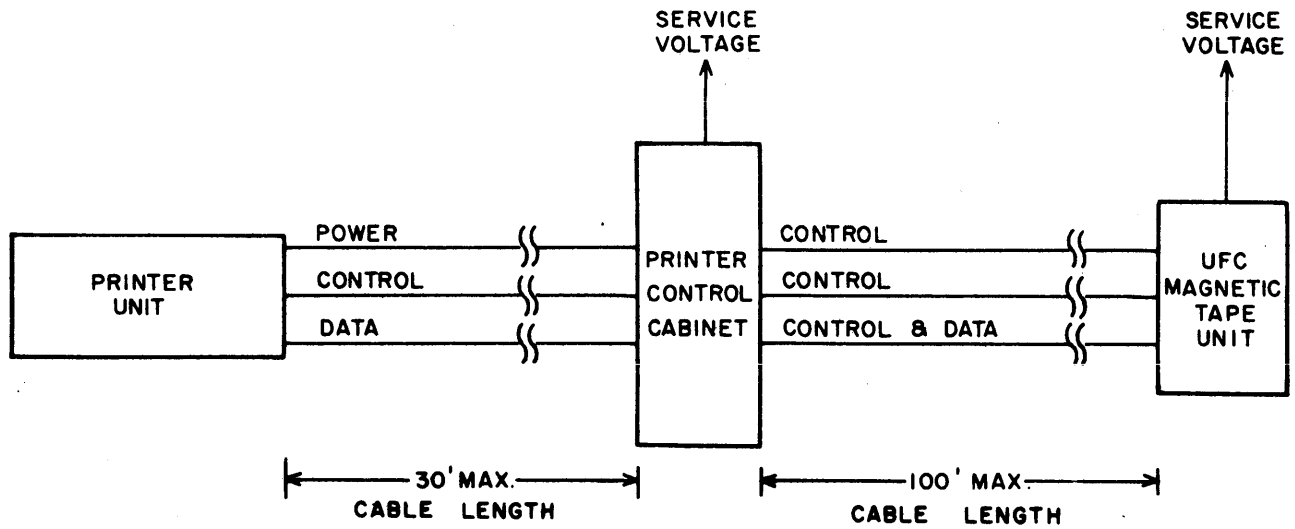

Figure 10-4. Cabling Diagram for Univac File-Computer High-Speed Printer (Off-Line Operation)